



CONTENTS

We want to thank our customers who use the Touch Operation Panel.

1. System configuration [Page 2](#)

Describes the devices required for connection, the setting of each device, cables, and configurable systems.

2. External device selection [Page 3](#)

Select a TOP model and an external device.

3. TOP communication setting [Page 4](#)

Describes how to set the TOP communication.

4. External device setting [Page 9](#)

Describes how to set up communication for external devices.

5. Cable table [Page 11](#)

Describes the cable specifications required for connection.

6. Supported addresses [Page 13](#)

Refer to this section to check the addresses which can communicate with an external device.

1. System configuration

The system configuration of TOP and "HITACHI EH-150/ MICRO-EH Series" is as follows:

Series	CPU	Link I/F	Communication method	System setting	Cable
HITACHI EH-150/ MICRO- EH Series	MICRO-EH	CPU Port	RS-232C RS-422 RS-485 (2 wire)	3. TOP communication setting 4. External device setting	5. Cable table
	EH-150 CPU316A				
	EH-150 Misc.				

■ Connectable configuration

- 1:1 connection



- 1:N connection



2. External device selection

- Select a TOP model and a port, and then select an external device.

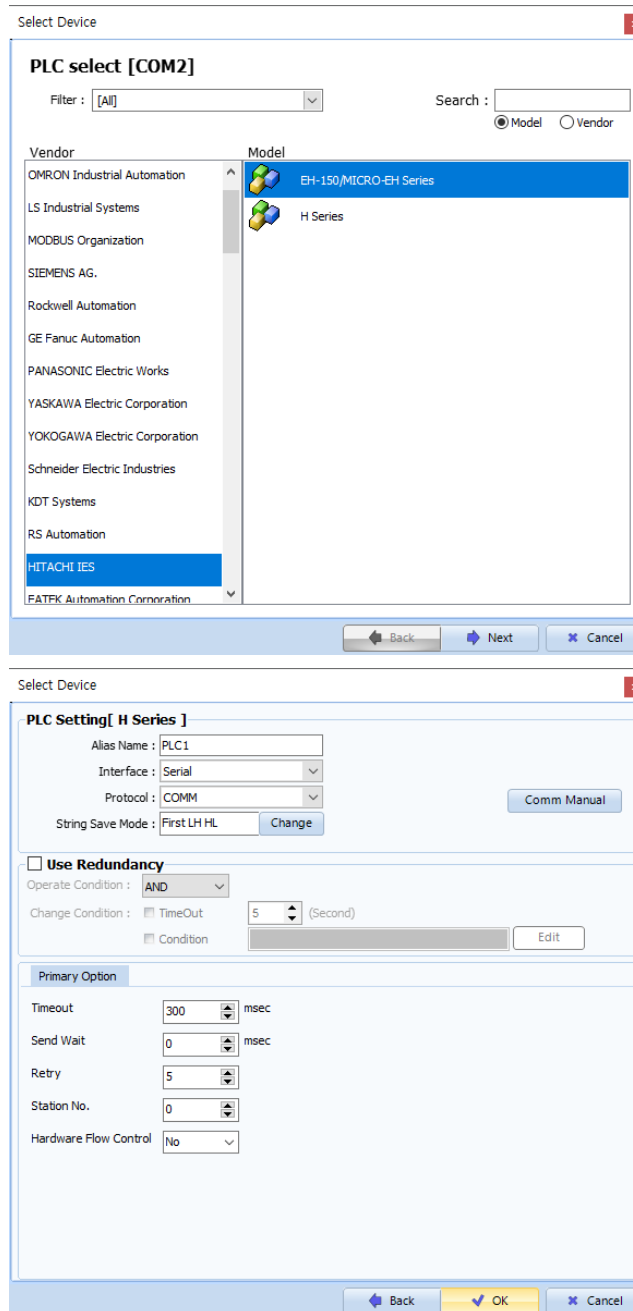

Settings		Contents
TOP	Model	Check the display and process of TOP to select the touch model.
External device	Vendor	Select the vendor of the external device to be connected to TOP. Select "HITACHI IES".
	PLC	Select an external device to connect to TOP. Select "EH-150/MICRO-EH Series". Please check the system configuration in Chapter 1 to see if the external device you want to connect is a model whose system can be configured.

3. TOP communication setting

The communication can be set in TOP Design Studio or TOP main menu. The communication should be set in the same way as that of the external device.

3.1 Communication setting in TOP Design Studio

(1) Communication interface setting

■ [Project > Project Property > TOP Setting] → [Project Options > "Use HMI Setup" Check > Edit > Serial]

– Set the TOP communication interface in TOP Design Studio.

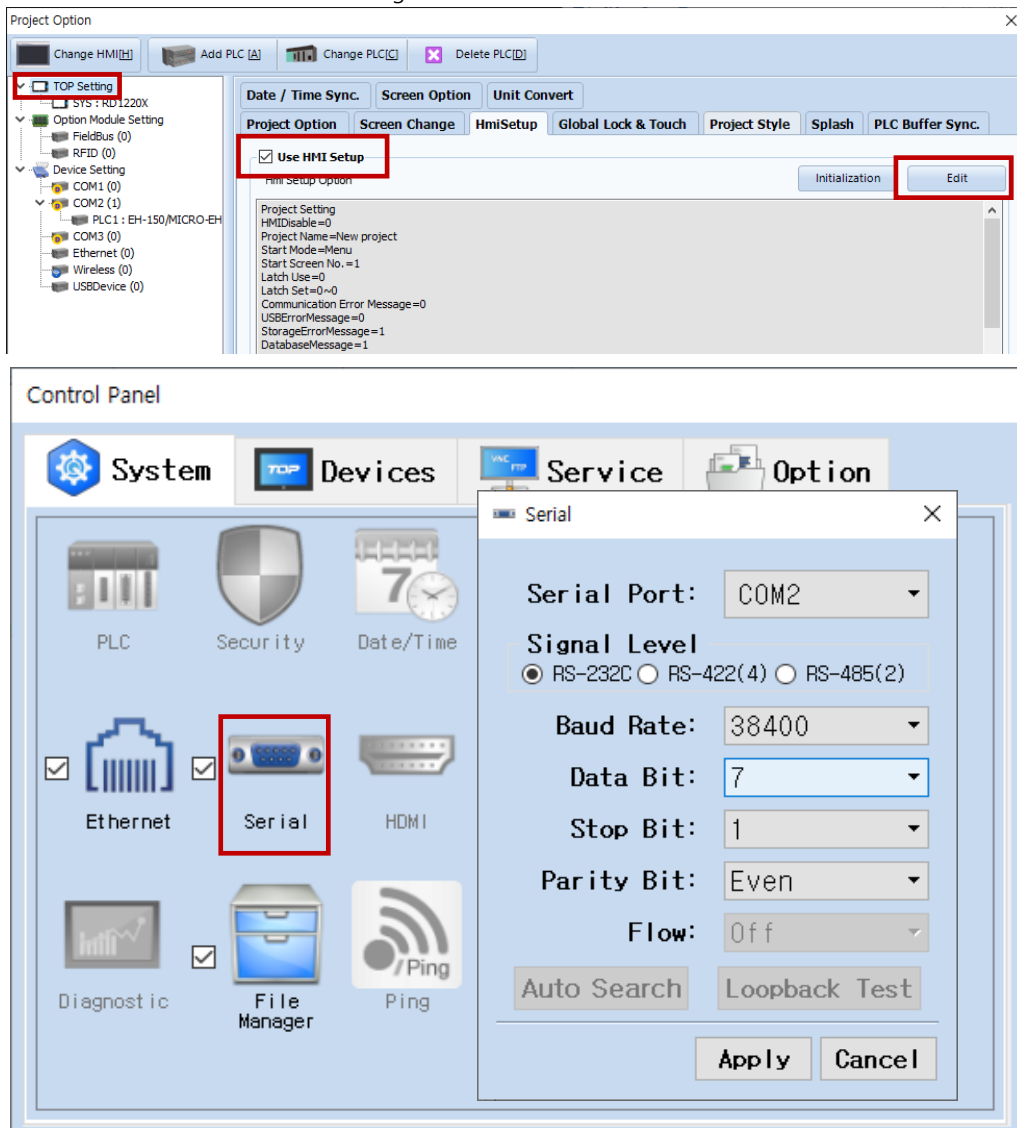

Items	TOP			External device	Remarks
	RS-232C	RS-422	RS-485		
Signal Level	RS-232C	RS-422	RS-485	RS-232C RS-422/485	
Baud Rate	38400				
Data Bit	7				
Stop Bit	1				
Parity Bit	EVEN				

* The above settings are examples recommended by the company.

Items	Description
Signal Level	Select the serial communication method between the TOP and an external device.
Baud Rate	Select the serial communication speed between the TOP and an external device.
Data Bit	Select the serial communication data bit between the TOP and an external device.
Stop Bit	Select the serial communication stop bit between the TOP and an external device.
Parity Bit	Select the serial communication parity bit check method between the TOP and an external device.

(2) Communication option setting

■ [Project > Project Property > Device Settings > COM > "PLC1 : EH-150/MICRO-EH Series"]

- Set the options of the HITACHI EH-150/MICRO-EH Series communication interface option in TOP Design Studio.

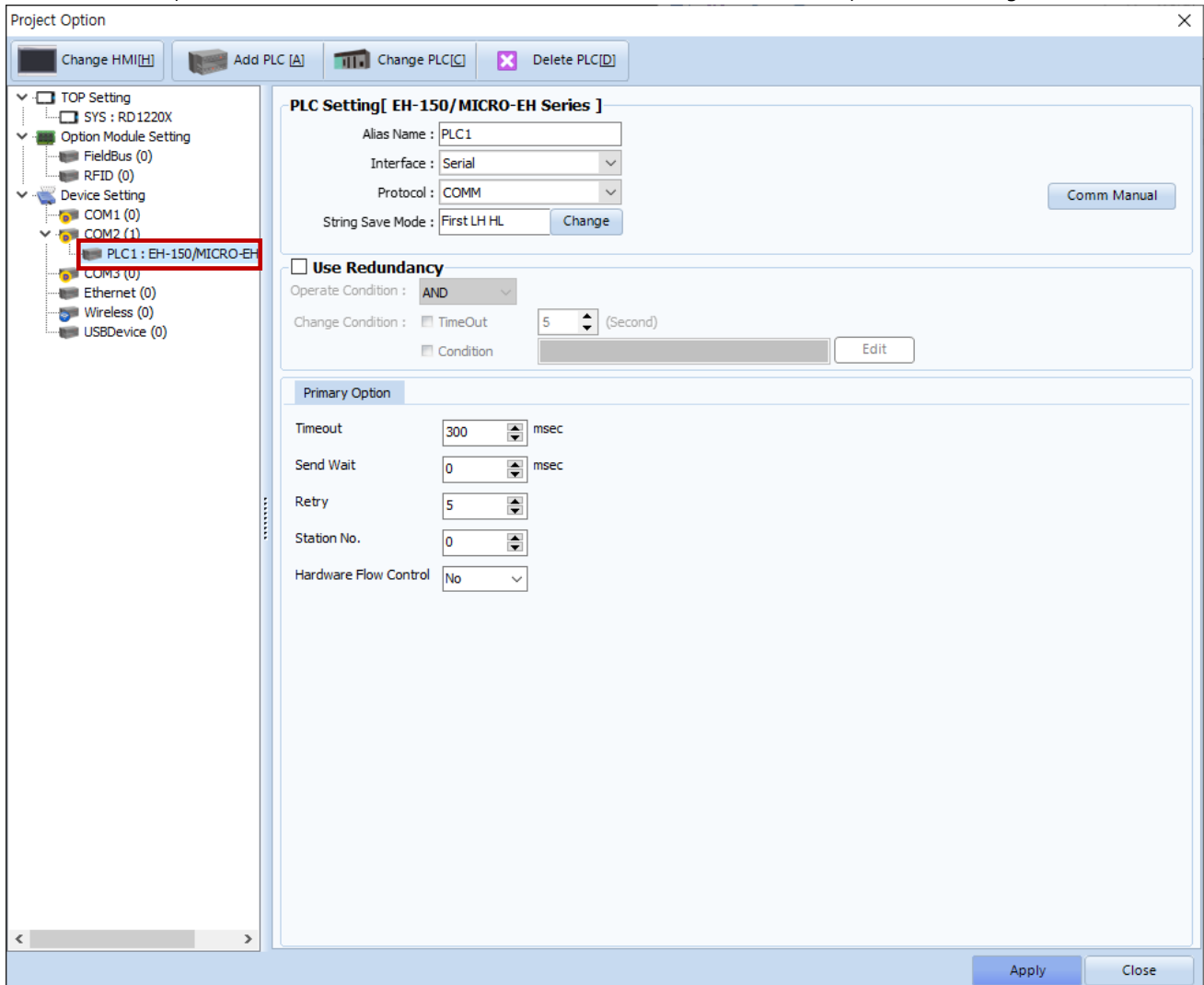

Items	Settings	Remarks
Interface	Select "Serial".	
Protocol	Select "COMM".	
TimeOut	Set the time for the TOP to wait for a response from an external device.	
SendWait	Set the waiting time between TOP's receiving a response from an external device and sending the next command request.	
Retry	Configure the amount of redelivery attempts from TOP to external device.	
Station No.	Prefix	
Hardware Flow Control	Set whether flow control exists in hardware.	Check CTS *Note 1)

***Note 1)** Confirm used communication port pin CTS.

3.2. Communication setting in TOP

* This is a setting method when "Use HMI Setup" in the setting items in "3.1 TOP Design Studio" is not checked.

- Touch the top of the TOP screen and drag it down. Touch "EXIT" in the pop-up window to go to the main screen.



(1) Communication interface setting

- [Main Screen > Control Panel > Serial]

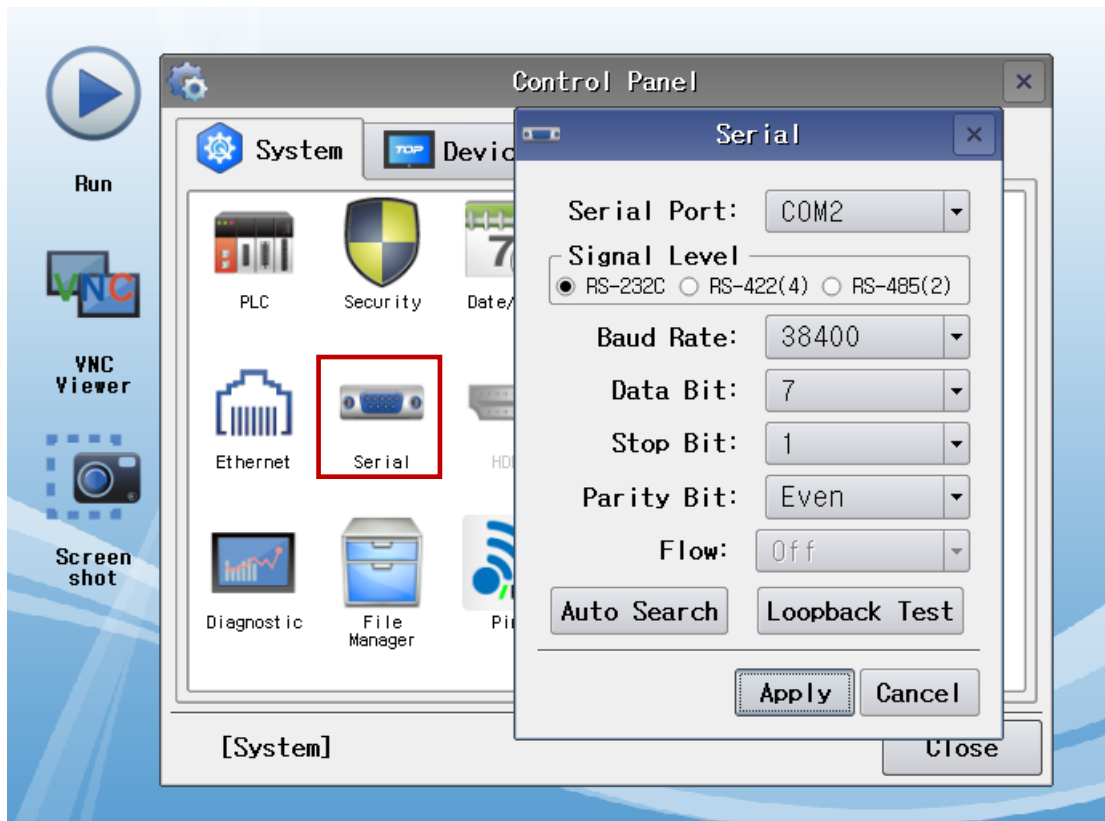

Items	TOP			External device	Remarks
Signal Level (port)	RS-232C	RS-422	RS-485	RS-232C RS-422/485	
Baud Rate	38400				
Data Bit	7				
Stop Bit	1				
Parity Bit	EVEN				

* The above settings are setting examples recommended by the company.

Items	Description
Signal Level	Select the serial communication method between the TOP and an external device.
Baud Rate	Select the serial communication speed between the TOP and an external device.
Data Bit	Select the serial communication data bit between the TOP and an external device.
Stop Bit	Select the serial communication stop bit between the TOP and an external device.
Parity Bit	Select the serial communication parity bit check method between the TOP and an external device.

(2) Communication option setting

■ [Main Screen > Control Panel > PLC]

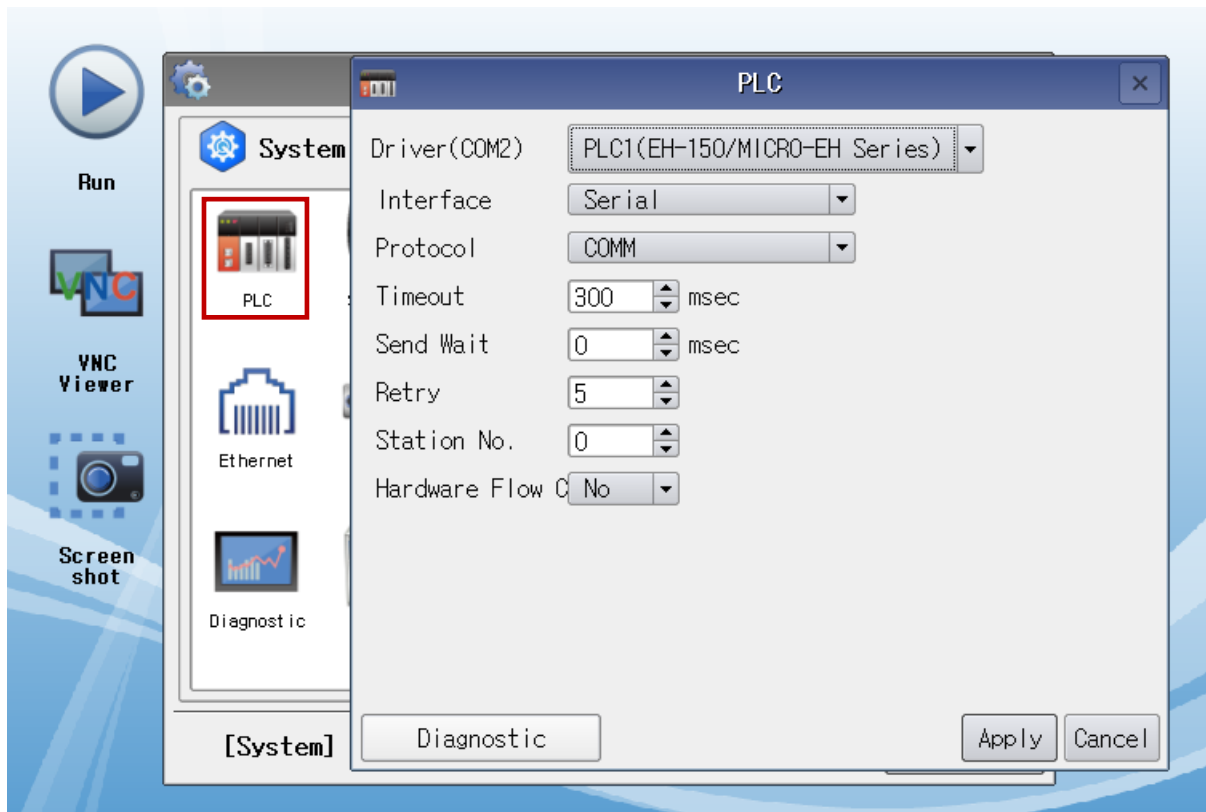

Items	Settings	Remarks
TimeOut	Set the time for the TOP to wait for a response from an external device.	
SendWait	Set the waiting time between TOP's receiving a response from an external device and sending the next command request.	
Retry	Configure the amount of redelivery attempts from TOP to external device.	
Station No.	Prefix	
Hardware Flow Control	Set whether flow control exists in hardware.	Check CTS *Note 1)

***Note 1)** Confirm used communication port pin CTS.

3.3 Communication diagnostics

- Check the interface setting status between the TOP and an external device.
 - Touch the top of the TOP screen and drag it down. Touch "EXIT" in the pop-up window to go to the main screen.
 - Check if the COM port settings you want to use in [Control Panel > Serial] are the same as those of the external device.

- Diagnosis of whether the port communication is normal or not
 - Touch "Communication diagnostics" in [Control Panel > PLC].
 - The Diagnostics dialog box pops up on the screen and determines the diagnostic status.

OK	Communication setting normal
Time Out Error	Communication setting abnormal - Check the cable, TOP, and external device setting status. (Reference: Communication diagnostics sheet)

- Communication diagnostics sheet
 - If there is a problem with the communication connection with an external terminal, please check the settings in the sheet below.

Items	Contents	Check		Remarks	
System configuration	How to connect the system	OK	NG	1. System configuration	
	Connection cable name	OK	NG		
TOP	Version information	OK	NG	2. External device selection 3. Communication setting	
	Port in use	OK	NG		
	Driver name	OK	NG		
	Other detailed settings	OK	NG		
	Relative prefix	Project setting	OK		NG
		Communication diagnostics	OK		NG
	Serial Parameter	Transmission Speed	OK		NG
Data Bit		OK	NG		
Stop Bit		OK	NG		
Parity Bit		OK	NG		
External device	CPU name	OK	NG	4. External device setting	
	Communication port name (module name)	OK	NG		
	Protocol (mode)	OK	NG		
	Setup Prefix	OK	NG		
	Other detailed settings	OK	NG		
	Serial Parameter	Transmission Speed	OK		NG
		Data Bit	OK		NG
		Stop Bit	OK		NG
Parity Bit		OK	NG		
Check address range		OK	NG	6. Supported addresses (For details, please refer to the PLC vendor's manual.)	

4. External device setting

For more detailed setting method than that described in this example, refer to the PLC user manual.

1. For communication with MICRO EH Series

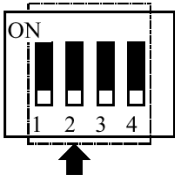

Number	1	2	3	4	Transmission Speed (bps)
DIP Switch	ON	OFF	ON	OFF	38400
	ON	OFF	OFF	OFF	19200
	OFF	OFF	ON	OFF	9600

In the MICRO EH Series, the 10-point base unit does not have a DIP switch, so the transmission speed is fixed at 38400 bps.

- For use of port 1, you must set WRF01A register as follows:

	15	14	13	12	11	10	9	8	7	6	5	4	3	2	1
WRF03D	a	b	c	d	e	f	g	h	i						

- For use of port 2 (RS-422/RS-485), you must set WRF03D register as follows:.

	15	14	13	12	11	10	9	8	7	6	5	4	3	2	1
WRF03D	a	b	c	d	e	f	g	h	i						

bit	value
a	0: Port 0, 1: Port 2
b	0 : Transmission control procedure 1, 1 : Transmission control procedure 2
c	0 : do not use prefix, 1 : use prefix (not used for port 1)
d, e, f	Not used
g, h	00 : 4800 bps, 01 : 9600 bps, 10 : 19200 bps, 11 : 38400 bps
i	Prefix (BCD 00 - 31) (not used for port 1)

※ Transmission Control Procedure (Procedure) 1 fixed.

2. For communication with EH-150 Series

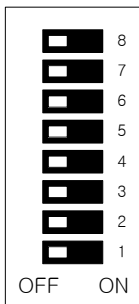

	Transmission Speed	1	2	3	4	5	6	T
Port1	9600			off	on	on		
	19200			on	off	on		
	38400			off	off	on		
Port2	9600						on	off
	19200						off	on
	38400						on	on

	15	14	13	12	11	10	9	8	7	6	5	4	3	2	1
WRF037	a	b	c	d	e	f	g	h	i						

bit	value
a	1
b	0 : Transmission control procedure 1, 1 : Transmission control procedure 2
c	0 : do not use prefix, 1 : use prefix (not used for port 1)
d	Not used
e, f	00
g, h	00 : RS-232, 01 : RS-422, 10 : RS-485
i	Prefix (BCD 00-31)

※ EH-150 CPU316A : Transmission Control Procedure (Procedure) 2, other : Transmission Control Procedure (Procedure) 1 Fixed.

5. Cable table

This chapter introduces a cable diagram for normal communication between the TOP and the corresponding device.
 (The cable diagram described in this section may differ from the recommendations of "EH-150/MICRO-EH Series")

■ RS-232C [MICRO-EH, EH-150 misc.]

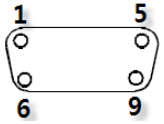
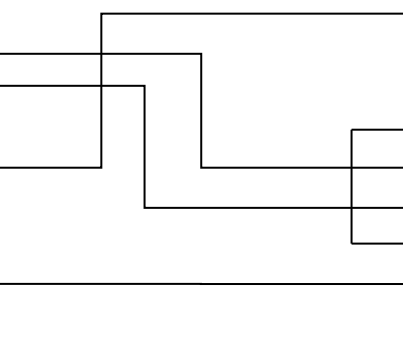
TOP			Cable connection	External device			
Pin arrangement* Note 1)	Signal name	Pin number		Pin number	Signal name	Pin arrangement* Note 1)	
 <p>Based on communication cable connector front, D-SUB 9 Pin male (male, convex)</p>				1	SG1		
	RD	2					
	SD	3					
	SG	5			4		CD1(DCD)
					5		SD1(TXD)
					6		RD1(RXD)
			7	DR1(DSR)			
	CTS	8		8	RS1(RTS)		

***Note 1)** The pin arrangement is as seen from the connecting side of the cable connection connector.

■ RS-232C [EH-150 : CPU316A]

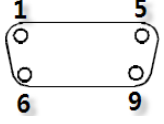
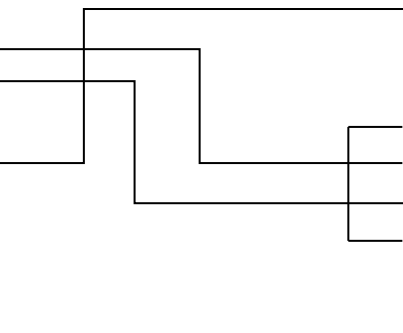
TOP			Cable connection	External device			
Pin arrangement* Note 1)	Signal name	Pin number		Pin number	Signal name	Pin arrangement* Note 1)	
 <p>Based on communication cable connector front, D-SUB 9 Pin male (male, convex)</p>				1	SG1		
	RD	2					
	SD	3					
	SG	5			4		CD1(DCD)
					5		SD1(TXD)
					6		RD1(RXD)
			7	DR1(DSR)			

***Note 1)** The pin arrangement is as seen from the connecting side of the cable connection connector.

■ RS-485 [MICRO-EH]

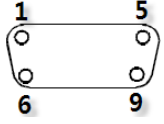
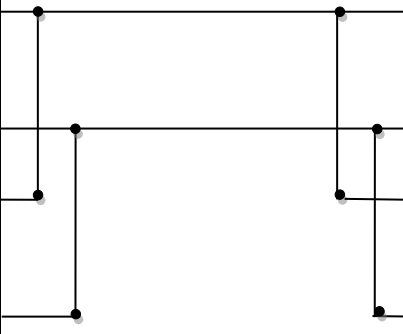
TOP			Cable connection	External device			
Pin arrangement* Note 1)	Signal name	Pin number		Pin number	Signal name	Pin arrangement* Note 1)	
 <p>Based on communication cable connector front, D-SUB 9 Pin male (male, convex)</p>	RDA	1		10	RDN		
	RDB	4			11		RDP
	SDA	6			12		SDN
					13		SDP
	SDB	9					

***Note 1)** The pin arrangement is as seen from the connecting side of the cable connection connector.

■ RS-422 [MICRO-EH]

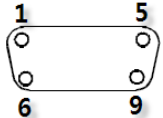
TOP			Cable connection	External device		
Pin arrangement* Note 1)	Signal name	Pin number		Pin number	Signal name	Pin arrangement* Note 1)
 <p>Based on communication cable connector front, D-SUB 9 Pin male (male, convex)</p>	RDA	1		13	SDP	
	RDB	4		12	SDN	
	SDA	6		11	RDP	
	SDB	9		10	RDN	

***Note 1)** The pin arrangement is as seen from the connecting side of the cable connection connector.

■ RS-485 [EH-150]

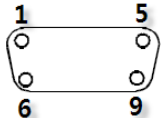
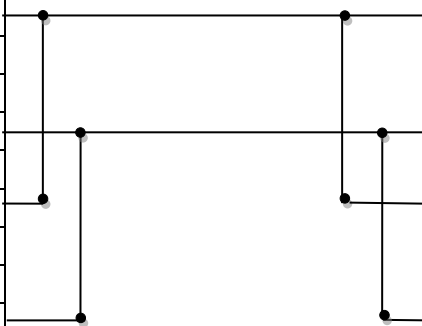
TOP			Cable connection	External device		
Pin arrangement* Note 1)	Signal name	Pin number		Pin number	Signal name	Pin arrangement* Note 1)
 <p>Based on communication cable connector front, D-SUB 9 Pin male (male, convex)</p>	RDA	1		4	TX	
	RDB	4		5	TXN	
	SDA	6		7	RX	
	SDB	9		6	RXN	

***Note 1)** The pin arrangement is as seen from the connecting side of the cable connection connector.

■ RS-422 [EH-150]

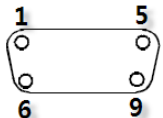
TOP			Cable connection	External device		
Pin arrangement* Note 1)	Signal name	Pin number		Pin number	Signal name	Pin arrangement* Note 1)
 <p>Based on communication cable connector front, D-SUB 9 Pin male (male, convex)</p>	RDA	1		4	TX	
	RDB	4		5	TXN	
	SDA	6		7	RX	
	SDB	9		6	RXN	

***Note 1)** The pin arrangement is as seen from the connecting side of the cable connection connector.

6. Supported addresses

The devices available in TOP are as follows:

The device range (address) may differ depending on the CPU module series/type. The TOP series supports the maximum address range used by the external device series. Please refer to each CPU module user manual and be take caution to not deviate from the address range supported by the device you want to use.

Device	Bit address	Word address	Remarks
X	X0000 ~ X4007	WX000 ~ WX400	External input
Y	Y0100 ~ Y4021	WY010 ~ WY401	External output
R	R0000 ~ R07BF	WR000 ~ WRFFF	Internal output
M	M0000 ~ M3FFF	WM000 ~ WM3FF	Data area
L	L0000 ~ L3FFF	WL000 ~ WL3FF	Link area
TC	TC0000.00 ~ TC2047.15	TC0000 ~ TC2047	Timer/Counter current value
CL	CL0000.00 ~ CL2047.15	CL0000 ~ CL2047	Counter clear
CU	CU0000 ~ CU2047	-	Up counter
RCU	RCU0000 ~ RCU2047	-	Ring counter
CTU	CTU0000 ~ CTU2047	-	Updown counter - Up input
CTD	CTD0000 ~ CTD2047	-	Updown counter - Down input
TD	TD0000 ~ TD1023	-	Delay timer
SS	SS0000 ~ SS1023	-	Single short timer
WDT	WDT0000 ~ WDT1023	-	Watchdog timer
MS	MS0000 ~ MS1023	-	Monostable timer
TMR	TMR0000 ~ TMR1023	-	Watchdog timer