

LS Industrial Systems

XGK / XBM / XBC Series

CPU Direct Driver

Supported version

TOP Design Studio

V1.0 or higher



CONTENTS

We would like to thank our customers for using M2I's "Touch Operation Panel (M2I TOP) Series". Read this manual and familiarize yourself with the connection method and procedures of the "TOP and external device".

1. System configuration [Page 2](#)

Describes the devices required for connection, the setting of each device, cables, and configurable systems.

2. External device selection [Page 3](#)

Select a TOP model and an external device.

3. TOP communication setting [Page 4](#)

Describes how to set the TOP communication.

4. External device setting [Page 9](#)

Describes how to set up communication for external devices.

5. Cable table [Page 10](#)

Describes the cable specifications required for connection.

6. Supported addresses [Page 11](#)

Refer to this section to check the addresses which can communicate with an external device.

1. System configuration

The system configuration of TOP and “LS Industrial Systems Co., Ltd – XGK / XBM / XBC Series CPU Direct” is as follows:

Series	CPU* Note 1	Link I/F	Communication method	System setting	Cable
XGK	XGK-CPUH XGK-CPUA XGK-CPUS XGK-CPUE XGK-CPUU	PADT connector (9 pin) *Note 2	RS232	3. TOP communication setting 4. External device setting	5. Cable table
XGB	XBM-D□16S XBM-D□32S XBC-D□32H XBC-D□64H	PADT connector (6 pin) *Note 2	RS232		

[*Note 1](#)) Check that the CPU unit is labeled as version V 1.1 or higher.

[*Note 2](#)) PADT Access connector: the PLC CPU connector used to connect to the PC Ladder S/W XG5000

■ Connection configuration (TOP connection–External device connection)

- 1:1 (one TOP and one external device) connection – configuration which is possible in RS232C communication.



2. External device selection

- Select a TOP model and a port, and then select an external device.

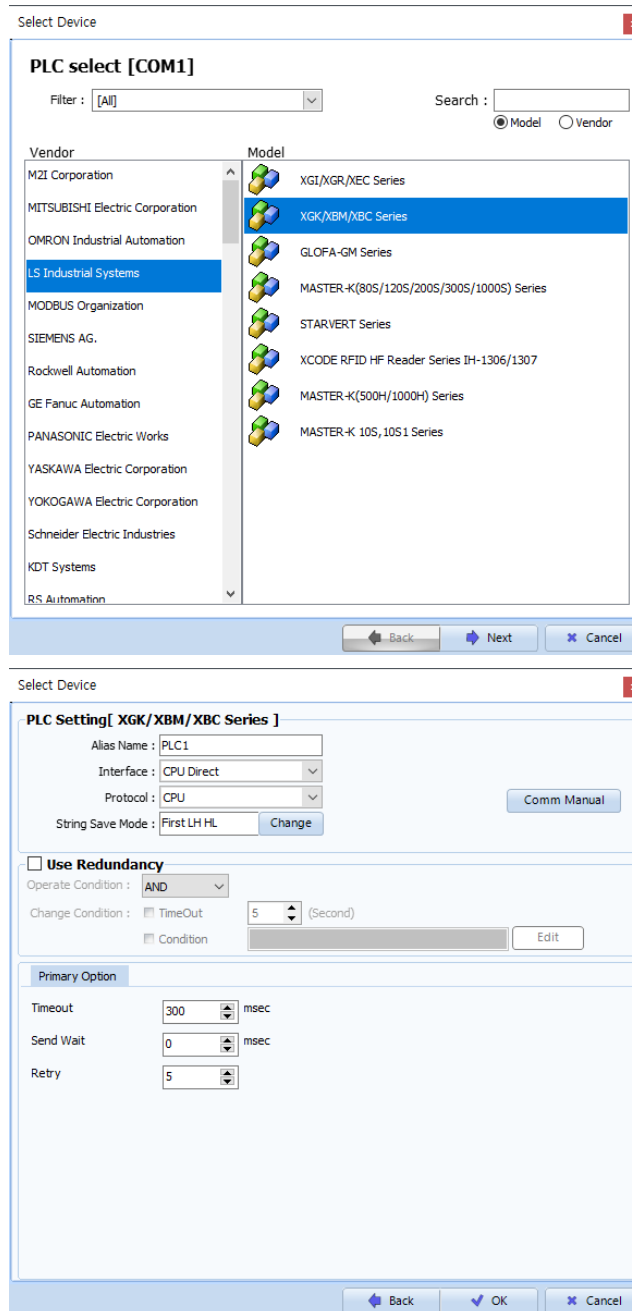

Settings		Contents					
TOP	Model	Check the TOP display and process to select the touch model.					
External device	Vendor	Select the vendor of the external device to be connected to TOP. Select "LS Industrial Systems".					
	PLC	Select an external device to connect to TOP. <table border="1" style="width: 100%; border-collapse: collapse;"> <thead> <tr> <th style="background-color: black; color: white;">Model</th> <th style="background-color: black; color: white;">Interface</th> <th style="background-color: black; color: white;">Protocol</th> </tr> </thead> <tbody> <tr> <td>XGK / XBM / XBC Series</td> <td>CPU Direct</td> <td>CPU</td> </tr> </tbody> </table> <p>Please check the system configuration in Chapter 1 to see if the external device you want to connect is a model whose system can be configured.</p>	Model	Interface	Protocol	XGK / XBM / XBC Series	CPU Direct
Model	Interface	Protocol					
XGK / XBM / XBC Series	CPU Direct	CPU					

3. TOP communication setting

The communication can be set in TOP Design Studio or TOP main menu. The communication should be set in the same way as that of the external device.

3.1 Communication setting in TOP Design Studio

(1) Communication interface setting

■ [Project > Project Property > TOP Setting] → [Project Option > "Use HMI Setup" Check > Edit > Serial]

– Set the TOP communication interface in TOP Design Studio.

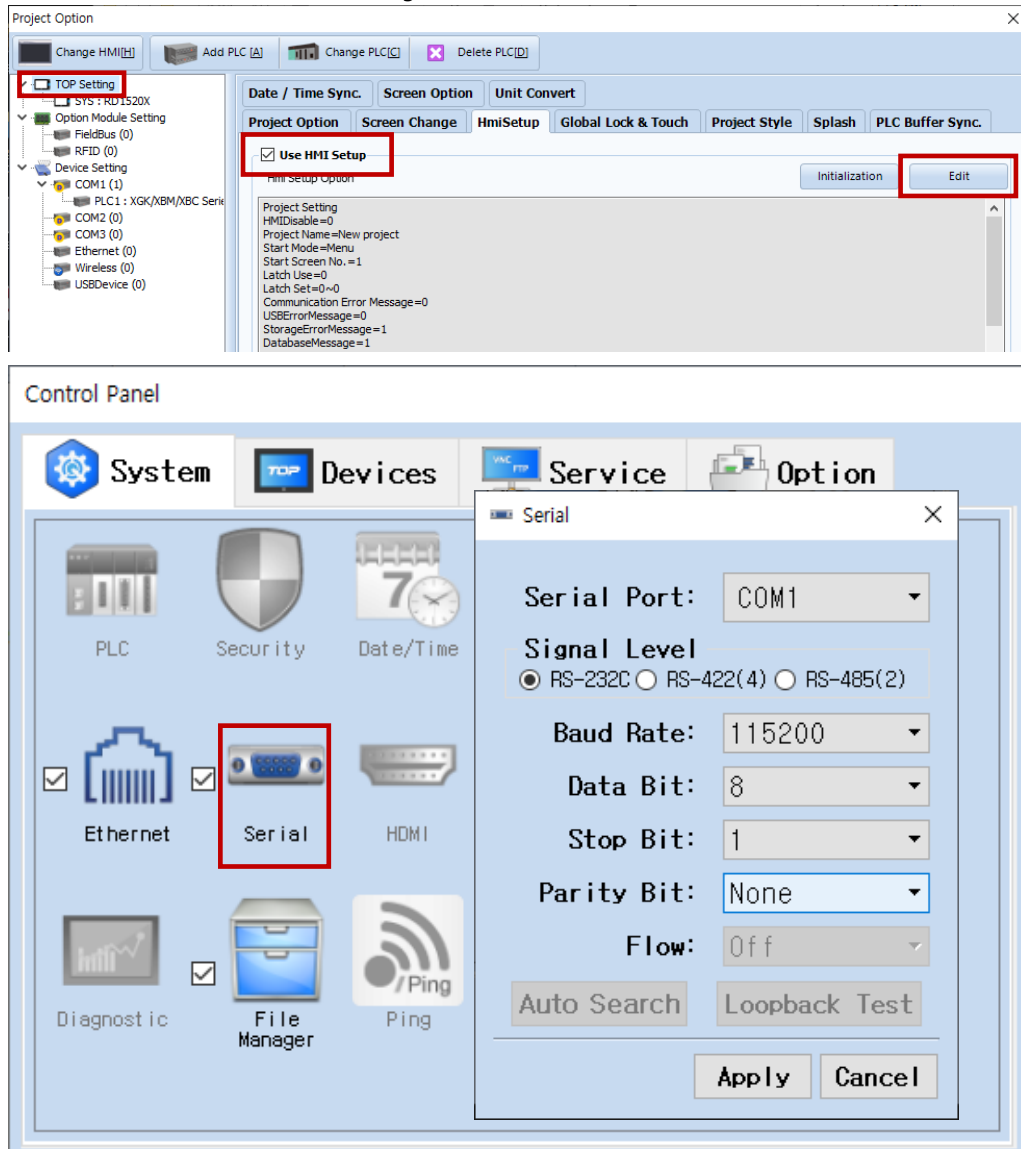

Items	TOP	External device	Remarks
Signal Level (port)	RS-232C	RS-232C (CPU port)	Fixed
Baud Rate		115200	Fixed
Data Bit		8	Fixed
Stop Bit		1	Fixed
Parity Bit		None.	Fixed

* The above settings are examples recommended by the company.

Items	Description
Signal Level	Select the serial communication method between the TOP and an external device.
Baud Rate	Select the serial communication speed between the TOP and an external device.
Data Bit	Select the serial communication data bit between the TOP and an external device.
Stop Bit	Select the serial communication stop bit between the TOP and an external device.
Parity Bit	Select the serial communication parity bit check method between the TOP and an external device.

(2) Communication option setting

■ [Project > Project Property > Device Setting > COM > "PLC1 : XGK/XBM/XBC Series"]

- Set the options of the XGK / XBM / XBC Series CPU Direct communication driver in TOP Design Studio.

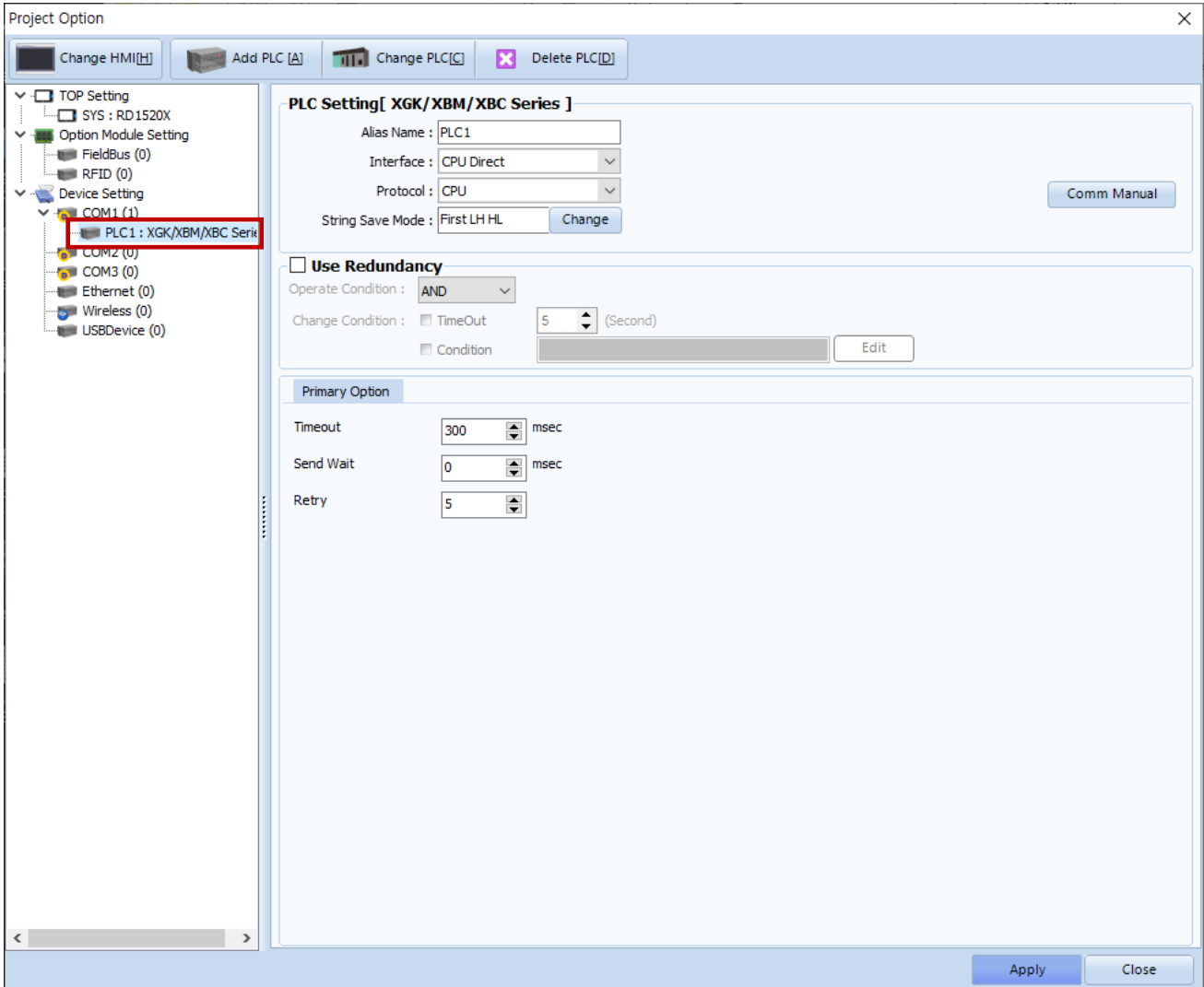

Items	Settings	Remarks
Interface	Select "CPU Direct".	Refer to "2. External device selection".
Protocol	Select "CPU".	
TimeOut (ms)	Set the time for the TOP to wait for a response from an external device.	
SendWait (ms)	Set the waiting time between TOP's receiving a response from an external device and sending the next command request.	

3.2. Communication setting in TOP

* This is a setting method when "Use HMI Setup" in the setting items in "3.1 TOP Design Studio" is not checked.

■ Touch the top of the TOP screen and drag it down. Touch "EXIT" in the pop-up window to go to the main screen.

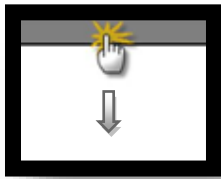

(1) Communication interface setting

■ [Main Screen > Control Panel > Serial]

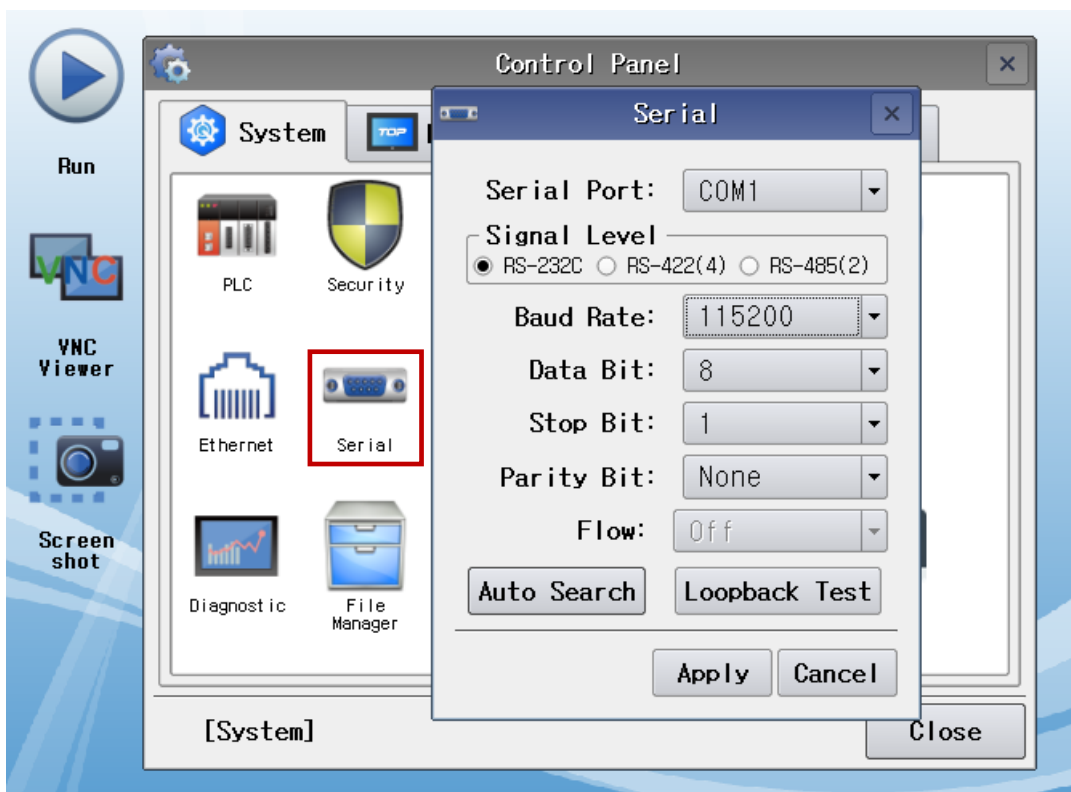

Items	TOP	External device	Remarks
Signal Level (port)	RS-232C	RS-232C (CPU port)	Fixed
Baud Rate		115200	Fixed
Data Bit		8	Fixed
Stop Bit		1	Fixed
Parity Bit		None.	Fixed

* The above settings are setting examples recommended by the company.

Items	Description
Signal Level	Select the serial communication method between the TOP and an external device.
Baud Rate	Select the serial communication speed between the TOP and an external device.
Data Bit	Select the serial communication data bit between the TOP and an external device.
Stop Bit	Select the serial communication stop bit between the TOP and an external device.
Parity Bit	Select the serial communication parity bit check method between the TOP and an external device.

(2) Communication option setting

■ [Main Screen > Control Panel > PLC]

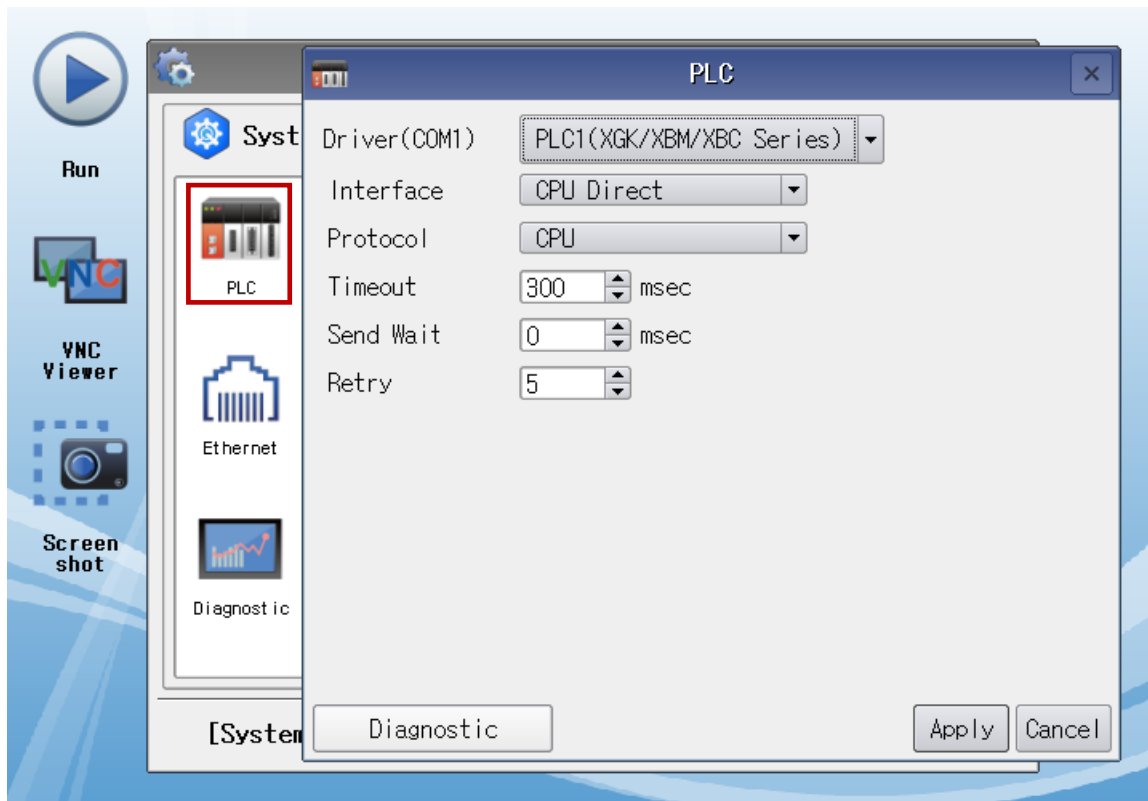

Items	Settings	Remarks
Interface	Select "CPU Direct".	Refer to "2. External device selection".
Protocol	Select "CPU".	Refer to "2. External device selection".
TimeOut (ms)	Set the time for the TOP to wait for a response from an external device.	
SendWait (ms)	Set the waiting time between TOP's receiving a response from an external device and sending the next command request.	

3.3 Communication diagnostics

- Check the interface setting status between the TOP and external device.
 - Touch the top of the TOP screen and drag it down. Touch "EXIT" in the pop-up window to go to the main screen.
 - Check if the COM port settings you want to use in [Control Panel > Serial] are the same as those of the external device.

- Diagnosis of whether the port communication is normal or not
 - Touch "Communication diagnostics" in [Control Panel > PLC].
 - The Diagnostics dialog box pops up on the screen and determines the diagnostic status.

OK	Communication setting normal
Time Out Error	Communication setting abnormal - Check the cable, TOP, and external device setting status. (Reference: Communication diagnostics sheet)

- Communication diagnostics sheet
 - If there is a problem with the communication connection with an external terminal, please check the settings in the sheet below.

Items	Contents	Check		Remarks	
System configuration	How to connect the system	OK	NG	1. System configuration	
	Connection cable name	OK	NG		
TOP	Version information	OK	NG	2. External device selection 3. Communication setting	
	Port in use	OK	NG		
	Driver name	OK	NG		
	Other detailed settings	OK	NG		
	Relative prefix	Project setting	OK		NG
		Communication diagnostics	OK		NG
	Serial Parameter	Transmission Speed	OK		NG
Data Bit		OK	NG		
Stop Bit		OK	NG		
Parity Bit		OK	NG		
External device	CPU name	OK	NG	4. External device setting	
	Communication port name (module name)	OK	NG		
	Protocol (mode)	OK	NG		
	Setup Prefix	OK	NG		
	Other detailed settings	OK	NG		
	Serial Parameter	Transmission Speed	OK		NG
		Data Bit	OK		NG
		Stop Bit	OK		NG
Parity Bit		OK	NG		
Check address range	OK	NG	6. Supported addresses (For details, please refer to the PLC vendor's manual.)		

4. External device setting

• Loader port communication interface of the "XGK / XBM / XBC Series" is fixed as the target configuration value of the following example.

5. Cable table

This chapter introduces a cable diagram for normal communication between the TOP and the corresponding device.
 (The cable diagram described in this section may differ from the recommendations of "LS Industrial Systems Co., Ltd.")

■ XGK RS-232C Port on CPU Unit (1:1 connection)

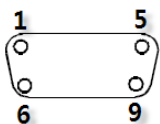
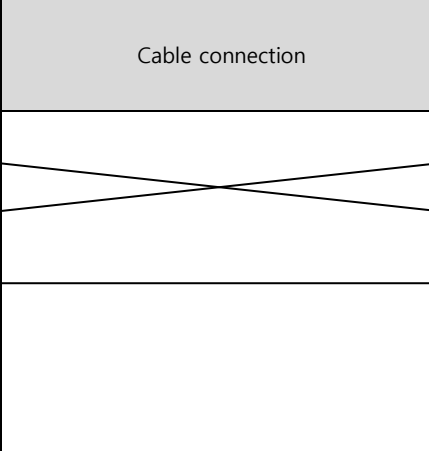
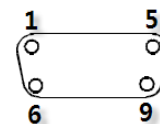
TOP COM			Cable connection	XGK RS-232C Port on CPU Unit		
Pin arrangement* Note 1)	Signal name	Pin number		Pin number	Signal name	Pin arrangement* Note 1)
 <p>Based on communication cable connector front, D-SUB 9 Pin male (male, convex)</p>	CD	1		1	CD	 <p>Based on communication cable connector front, D-SUB 9 Pin male (male, convex)</p>
	RD	2		2	RD	
	SD	3		3	SD	
	DTR	4		4	DTR	
	SG	5		5	SG	
	DSR	6		6	DSR	
	RTS	7		7	RTS	
	CTS	8		8	CTS	
		9		9		

***Note 1)** The pin arrangement is as seen from the connecting side of the cable connection connector.

■ XGB (XBM/XBC) RS-232C Port on CPU Unit (1:1 connection)

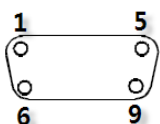
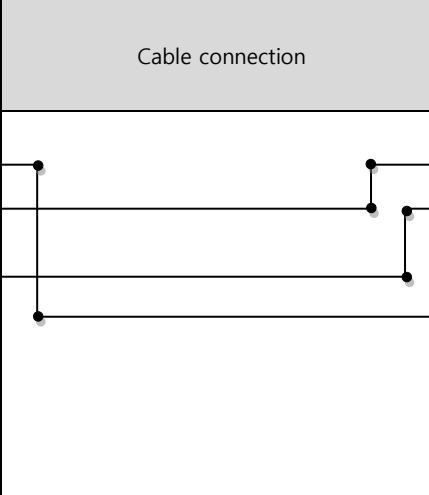
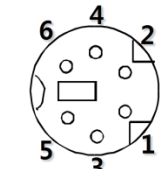
TOP COM			Cable connection	XGB RS-232C Port on CPU Unit			
Pin arrangement* Note 1)	Signal name	Pin number		Pin number	Signal name	Pin arrangement* Note 1)	
 <p>Based on communication cable connector front, D-SUB 9 Pin male (male, convex)</p>	CD	1		1		 <p>Based on communication cable connector front, D-SUB 6 Pin male (male, convex)</p>	
	RD	2		2	RD		
	SD	3		3	3		SG
	DTR	4		4	4		
	SG	5		5	5		
	DSR	6		6	6		SD
	RTS	7		7			
	CTS	8		8			
		9		9			

***Note 1)** The pin arrangement is as seen from the connecting side of the cable connection connector.



6. Supported addresses

The devices available in TOP are as follows:

The device range (address) may differ depending on the CPU module series/type. The TOP series supports the maximum address range used by the external device series. Please refer to each CPU module user manual and be take caution to not deviate from the address range supported by the device you want to use.

Device	Bit Address	Word Address	Remark
Input/Output Relay	P0 – P4095F	P0 – P4095	
Auxiliary Relay	M0 – M4095F	M0 – M4095	
Keep Relay	K0 – K4095F	K0 – K4095	
Special Relay	F0 – F4095F	F0 – F4095	Cannot be written
Timer(Contact)	T0 – T8191	——	
Counter(Contact)	C0 – C8191	——	
Timer(Elapsed Value)	——	T0 – T8191	
Counter(Elapsed Value)	——	C0 – C8191	
Special Module Register	U0.0.0 – U7F.31.F	U0.0 – U7F.31	
Index Register	——	Z0 – Z255	
Step Controller	——	S0 – S255	
Link Relay	L0 – L11263F	L0 – L11263	
Communication Register	——	N0 – N21503	
Data Register	D0.0 – D524287.F	D0 – D524287	
File Register	R0.0 – R32767.F	R0 – R32767	
File Register	ZR0 – ZR524287.F	ZR0 – ZR524287	

*The lower 16 BIT data of 32 BIT data is saved in the address whose screen has been registered, and the upper 16 BIT data is saved in the address next to the address whose screen has been registered.

Ex. When saving 32 BIT data hexadecimal data 12345678 in address D00100, it is saved to 16 BIT device address as follows:

Items	32BIT	16BIT	
		D00100	D00101
Address	D00100	D00100	D00101
Input data (hexadecimal)	12345678	5678	1234