

LS Industrial Systems Co., Ltd.

XGT(XGI-CPU/XGR-CPU), XGB(XEC-CPU) Series

FENET Driver

Support version OS V4.0 이상



XDesignerPlus 4.0.0.0 이상

CONTENTS

Thank you for using TOP series of M2I corporation.
Please read this manual carefully to know connection methods and procedures of "TOP to External device"

1. System configuration Page 2



A section for showing connectable external devices, serial signal types, connection configurations. Refer this section to select the right system configuration.

2. Selection of TOP, External device Page 3



A section for selecting a Top model and the external device.

3. Example of system setting Page 4

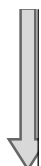

A section for explaining examples to connect communications of TOP to External Device.

Select the correct example in your case according to "1. System configuration".

4. Communication setting Page 8

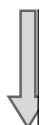

A section for Communication setting.

The setting should be the same with the external device.

5. Usable address Page 10

A section for usable address to communicate with external device.

1. System configuration

System configuration of TOP and "LS Industrial Systems Co., Ltd – XGT(XGK), XGB(XBC/XBM) Series" is as below.

Series	CPU	Link I/F	Communication type	System setting	cable
XGI XGR	XGI-CPUE XGI-CPUH XGI-CPUS XGI-CPUU XGI-CPUU/D XGR-CPUH	XGL-EFMT	Ethernet (UDP)	setting ex 1 (4 page)	Twist pair cable ^{*1)}
			Ethernet (TCP)	setting ex 2 (6 page)	
XGB	XEC-D□32H XEC-D□64H	XGL-EMTA	Ethernet (UDP)	setting ex 1 (4 page)	
			Ethernet (TCP)	setting ex 2 (6 page)	

*1) Twist pair cable

- It means STP(shield twist pair cable) or UTP(shieldless twist pair cable) category 3, 4, 5.
- It can connect to hub, transceiver etc. according to network composition and use direct cable in this case.

■ Connection configuration

- 1 : 1 connection (TOP 1 unit to External device 1 unit)

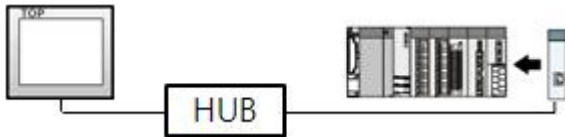

- 1 : N connection (TOP 1 unit to External device several units)

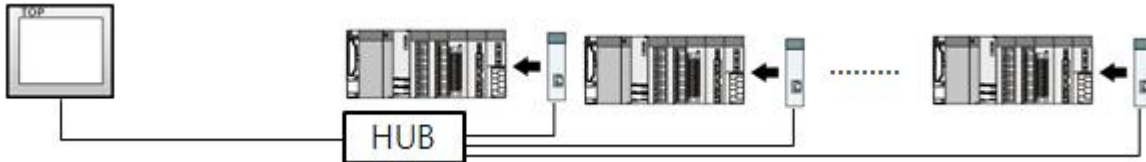

2. Selection of TOP, External device

Select a external device which is communicated to the TOP.

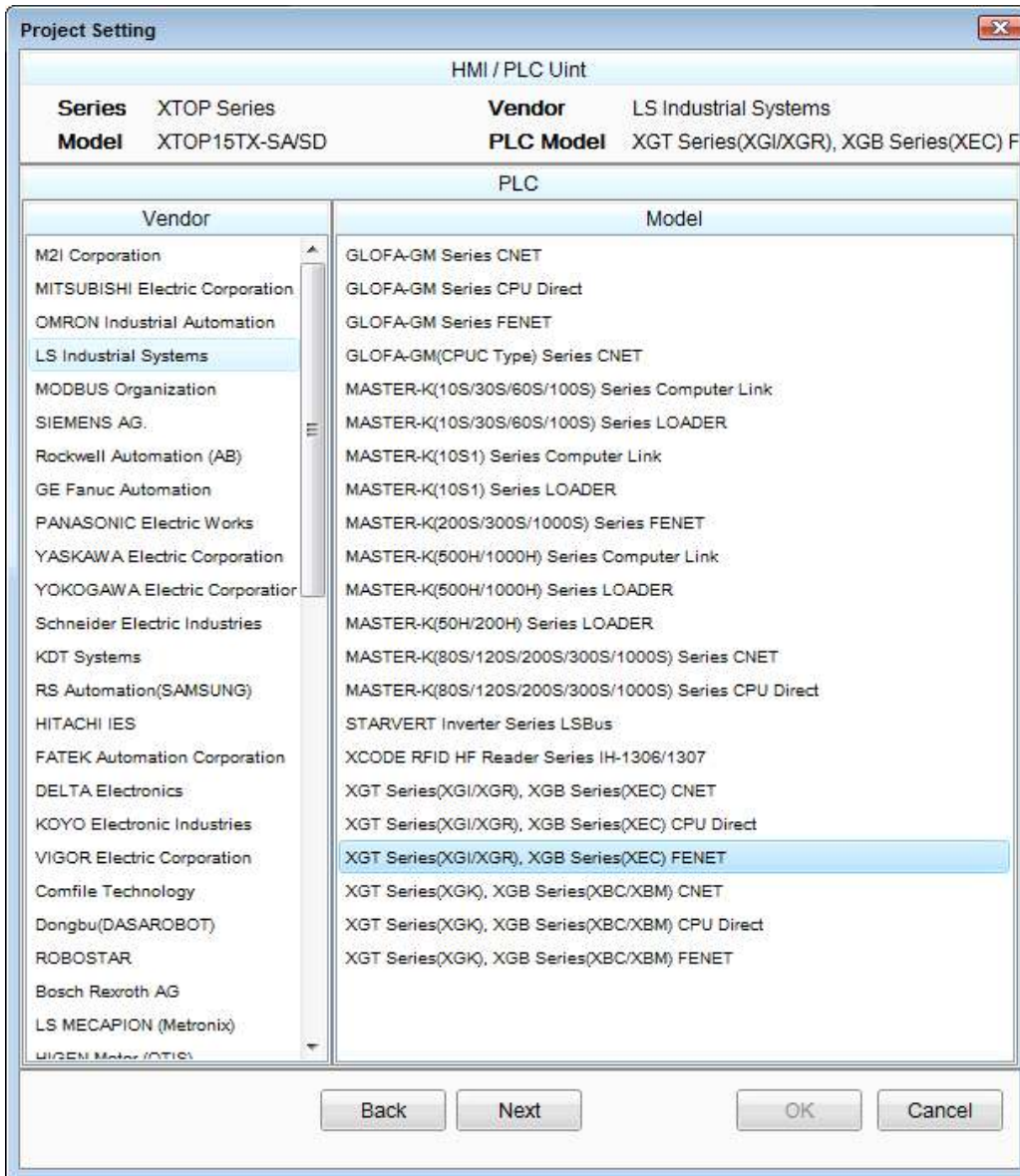

Setting Items		Description				
TOP	Series	Select a TOP series which is communicated with external device. Install an OS file v3.1 as diagram below before download a project file you have made. <table border="1" data-bbox="512 1626 1150 1715"> <tr> <td>Series</td> <td>OS Version</td> </tr> <tr> <td>XTOP / HTOP</td> <td>V4.0</td> </tr> </table>	Series	OS Version	XTOP / HTOP	V4.0
	Series	OS Version				
XTOP / HTOP	V4.0					
	Name	Select a TOP model which is communicated with external device.				
External Device	Vendor	Select vendor of the external device which is communicated with TOP. Select " <u>LS Industrial Systems Co., Ltd</u> ".				
	PLC	Select a model name of the external device which is communicated with TOP. Select " <u>XGT(XGI/XGR), XGB(XEC) Series</u> ". Check whether the external device you want to use is connectable or not in "1. System configuration".				

3. System setting

Set Communication interface of TOP and external device as below.

3.1 Example 1

Set your system as below.

Item	TOP	XGT(XGI/XGR), XGB(XEC) Series	Note
IP Address*1)2)	192.168.0.50	192.168.0.51	User Set
Protocol	UDP	XGT server*3)	User Set
Port	1024	2005	User Set

*1) Network address TOP and external device must be same. (IP's three place : 192.168.000)

*2) Don't use same address in same network.

*3) XGT driver private port of FENET I/F module admits communication to specified port number/protocol to appropriate IP.

Protocol	TCP/IP	UDP/IP	MODBUS TCP
Port number	2004	2005	502

(1) XDesignerPlus Setting

[Project >Project property] of XDesignerPlus as below and download it to TOP machine.

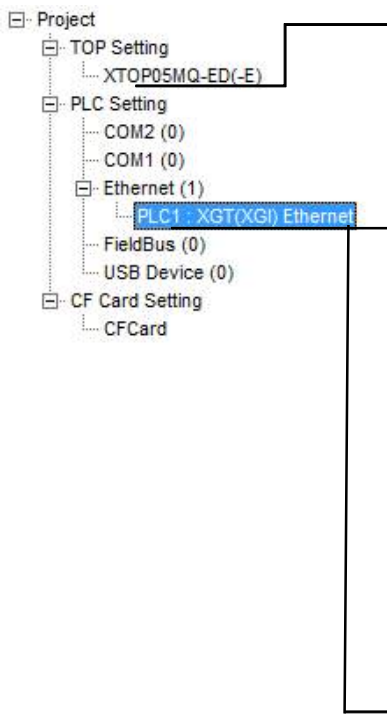

■ [Project > Project property > project > TOP Setting > TOP's Name]

Set communication interface of TOP.

- From right window [HMI Setup > check Use HMI Setup > Device Manager]

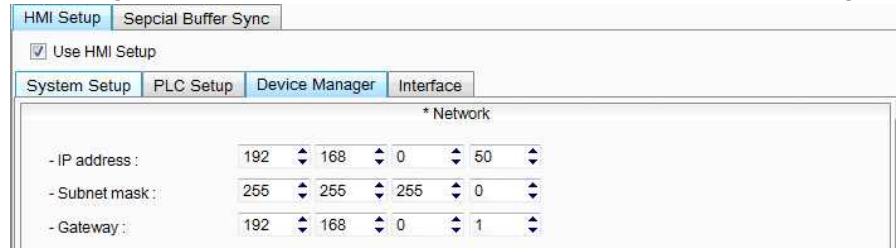

- From right window [HMI Setup > check Use HMI Setup > PLC Setting]

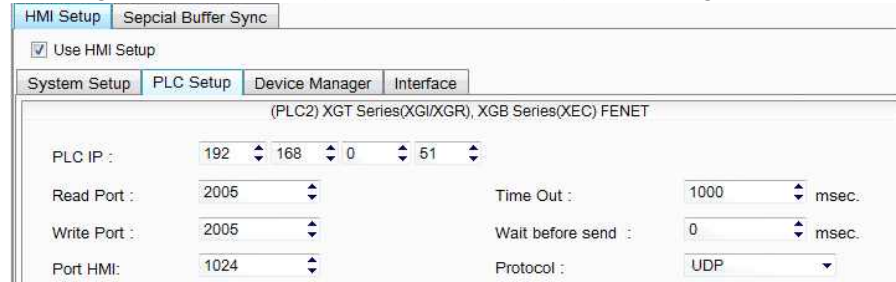

■ External Device Settings

Set up the "XGT(XGI/XGR), XGB(XEC) Series FENET" communication option

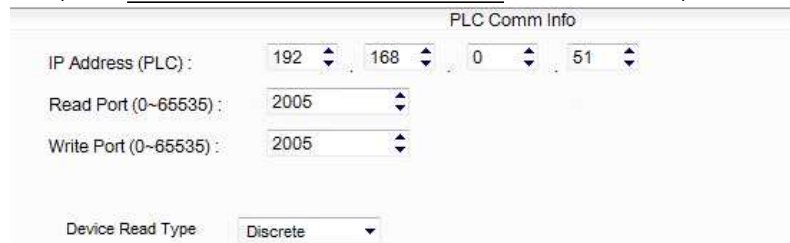

- IP Address (PLC): Type the IP address that the external device was given.

- Reading port / writing port: Choose the port number that will be used for ethernet communication. Please input the port number that [GPPW] issued.

- Device reading method : It is for selecting protocol method that will attempt

to communicate to external device.

(2) External device setup

Run "XG-PD Editor" program for communication setting and set as below.

If you want to change communication interface, modify refer to PLC manual.



Don't use overlapping IP address in unit network.

1. Run File > New File". Select CPU Type and push OK button refer to "1. system configuration".
2. Connect CPU LOADER port of XGT Series and serial port of PC by serial cross cable.
(If there is USB port in CPU, connect USB.)
3. Run [Online] > [Connection settings] menu. Select [Connection settings->Type] and click [Connect] button.
4. Run [Online] > [I/O Information] and read slot number. Run [Online] > [Read Parameter] and read parameter information of slot of communication card.
5. Double click slot of Cnet card in [Project Window], show dialog box of [Default settings].
Set [Connection] and [Run Mode] as below and click [OK].



Item	Contents		Note	
TCP/IP setting	High speed link station number	0	Set station number when it communicated to high speed between XGT PLC FEnet I/F module and module.	
	Media	AUTO	Select media.	
	IP address	192.168.0.51	Set IP address of FEnet I/F module.	Required setting
	Subnet mask	255.255.255.0	Subnet mask	
	Gateway	192.168.0.1	Gateway address(Router address)	
	DNS server	0.0.0.1	Domain name server	
	DHCP	OFF (default)	If you use automatically assigned IP, check "ON".	Required setting
	Receive Wait time	15 (default)		
Personal connection unit	3 (default)	Maximum number of private service that can connect simultaneously.		
Driver(server) setting	Driver	XGT server	Required setting	

Host table setting	Unable Host table	OFF	Module of registered IP address is only admitted connection to FEnet I/F.(If it is unable, unregistered client can't connect.)	Required setting
--------------------	----------------------	-----	--------------------------------------------------------------------------------------------------------------------------------	------------------

6. Transfer setting contents to CPU at [Online] > [Parameter Write].
7. Reset PLC at [Online] > [Reset] > [Reset PLC].

3.2 Example 2

Set your system as below.

Item	TOP	XGT(XGI/XGR), XGB(XEC) Series	Note
IP Address*1)2)	192.168.0.50	192.168.0.51	User set
Protocol	TCP	XGT server*3)	User set
Port	1024	2004	User set

*1) Network address TOP and external device must be same. (IP's three place : 192.168.000)

*2) Don't use same address in same network.

*3) XGT driver private port of FENET I/F module admits communication to specified port number/protocol to appropriate IP.

Protocol	TCP/IP	UDP/IP	MODBUS TCP
Port number	2004	2005	502

(1) XDesignerPlus setting

[Project > Project property] of XDesignerPlus as below and download it to TOP machine.

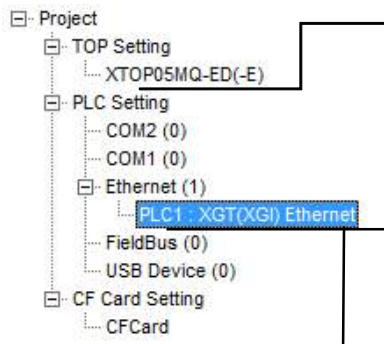

■ [Project > Project property > project > TOP Setting > TOP's Name]

Set communication interface of TOP.

- From right window [HMI Setup > check Use HMI Setup > Device Manager]

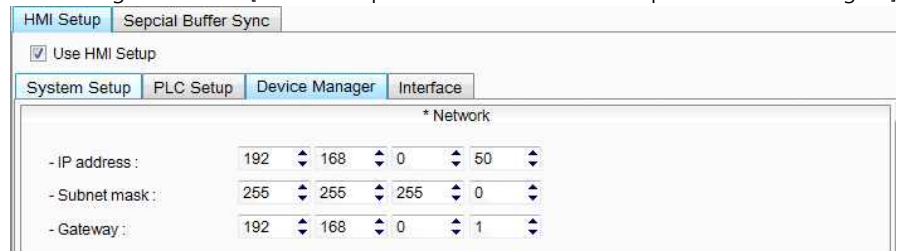

- From right window [HMI Setup > check Use HMI Setup > PLC Setting]

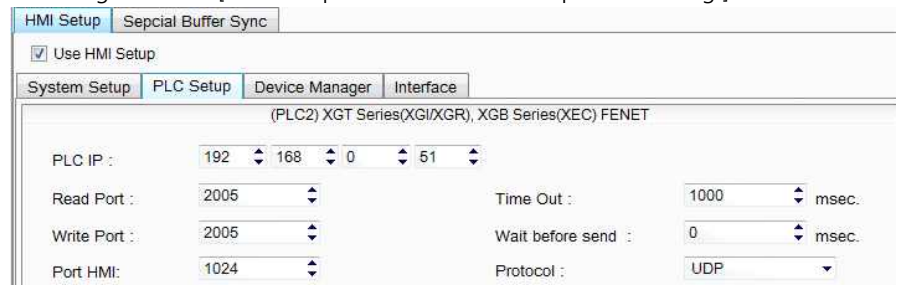

■ External Device Settings

Set up the "XGT(XGI/XGR), XGB(XEC) Series FENET" communication option

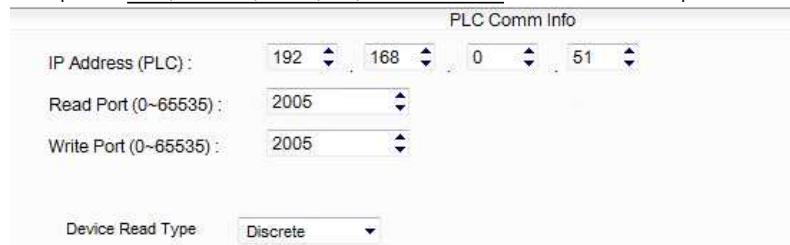

- IP Address (PLC): Type the IP address that the external device was given.
- Reading port / writing port: Choose the port number that will be used for ethernet communication. Please input the port number that [GPPW] issued.
- Device reading method : It is for selecting protocol method that will attempt to communicate to external device.

(2) External device setup

Run "XG-PD Editor" program for communication setting and set as below.

If you want to change communication interface, modify refer to PLC manual.



Don't use overlapping IP address in unit network.

1. Run File > New File". Select CPU Type and push OK button refer to "1. system configuration".
2. Connect CPU LOADER port of XGT Series and serial port of PC by serial cross cable.
(If there is USB port in CPU, connect USB.)
3. Run [Online] > [Connection settings] menu. Select [Connection settings->Type] and click [Connect] button.
4. Run [Online] > [I/O Information] and read slot number. Run [Online] > [Read Parameter] and read parameter information of slot of communication card.
5. Double click slot of Cnet card in [Project Window], show dialog box of [Default settings]. Set [Connection] and [Run Mode] as below and click [OK].



Item	Contents		Note	
TCP/IP setting	High speed link station number	0	Set station number when it communicated to high speed between XGT PLC FEnet I/F module and module.	
	Media	AUTO	Select media.	
	IP address	192.168.0.51	Set IP address of FEnet I/F module.	Required setting
	Subnet mask	255.255.255.0	Subnet mask	
	Gateway	192.168.0.1	Gateway address(Router address)	
	DNS server	0.0.0.1	Domain name server	
	DHCP	OFF (default)	If you use automatically assigned IP, check "ON".	Required setting
	Receive Wait time	15 (default)		
Personal connection unit	3 (default)	Maximum number of private service that can connect simultaneously.		
Driver(server) setting	Driver	XGT server	Required setting	
Host table setting	Unable Host table	OFF	Module of registered IP address is only admitted connection to FEnet I/F.(If it is unable, unregistered client can't connect.)	Required setting

6. Transfer setting contents to CPU at [Online] > [Write].
7. Reset PLC at [Online] > [Reset PLC].

item	Description
Serial Signal Level	Setup signal level(RS-232C/422/485) of PLC connected with COM2/1 port. (COM1 only RS-232C)
Serial Baud Rate	Setup [communications Baud rate] of PLC connected with COM2/1 port.
Serial Data Bit	Setup [Data Bit] of PLC connected with COM2/1 port.
Serial Stop Bit	Setup [Stop Bit] of PLC connected with COM2/1 port.
Serial Parity Bit	Setup [Parity Bit] of PLC connected with COM2/1 port.
Time Out [x100 mSec]	Setup [Time Out] of PLC connected with COM2/1 port. (Timeout:: waiting time for answer of PLC)
Send Wait [x10 mSec]	Setup [Send Wait] of PLC connected with COM2/1 port. (Send Wait: communicate after waiting setting time when touch screen requires communications.)
Station Num. in Diag.[0~31]	Setup [Station Num.(0~31)] using "4.3 Communication Diagnosis"

4. Communication setting

Communication setup can be set on XDesignerPlus or TOP Main Menu. The setting should be the same with the external device.

(1) XDesignerPlus setup – register information of external device

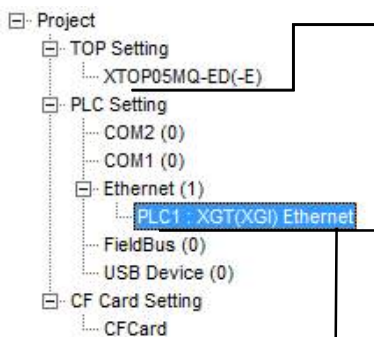

■ [Project > Project property > project > TOP Setting > TOP's Name]

Set communication interface of TOP.

- From right window [HMI Setup > check Use HMI Setup > Device Manager]

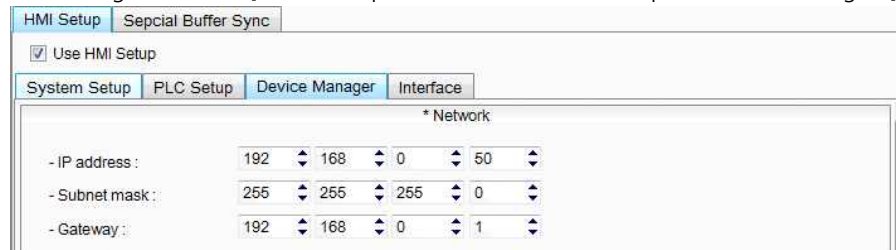

- From right window [HMI Setup > check Use HMI Setup > PLC Setting]



■ External Device Settings

Set up the "XGT(XGI/XGR), XGB(XEC) Series FENET" communication option

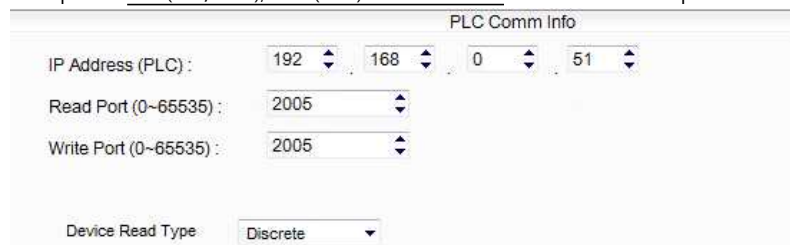

■ Setting communication Interface

4.2 TOP main menu setup item

- When a buzzer is on during the power reset, touch 1 spot at the upper LCD to move to "TOP Management Main" display.
- Set up driver interface at TOP according to below **Step1** → **Step2**.
(Press "TOP ethernet setup" in **Step 1** to change setup at **Step 2**.)

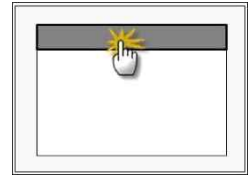

Step 1. [PLC setup] .Setup driver interface.

PLC setup	
PLC IP : 192 . 168 . 0 . 51	Communication Interface Settings
Protocol : UDP	
PLC Read Port : 2005	
PLC Write Port : 2005	
TOP Port : 1024	
PLC Address : 00	
Timeout : 1000 [mSec]	
Delay time of transmission : 0 [mSec]	
TOP IP : 192 . 168 . 0 . 50	
TOP Ethernet setting communication diagnosis	

Step 1-Reference.

Details	Contents
PLC IP	It is an IP address that external device was given.
Protocol	Select the protocol method either UDP or TCP.
PLC Read Port	It is the port address that will be used for ethernet of external device.
PLC Write Port	It is the port address that will be used for ethernet of external device.
TOP port	Setting the TOP port number to connect with external device.
PLC address [0~65535]	Address of other device. Select between [0 - 65535].
Timeout [x1 mSec]	Set up TOP's waiting time from external device at [0 - 5000] x 1mSec.
Delay Time before transmitting [x1 mSec]	Set up TOP's waiting time between response receiving – next command request transmission from external device at [0 – 5000] x 1 mSec.
TOP IP	Setup the IP address that TOP receives in the network.

Step 2. [PLC Setup] > [TOP Ethernet Setup] - Setup the serial parameter of correspond port.

Port Settings	
* Ethernet Communication	Ethernet Port Communication Interface Settings
+ Network setting	
- MAC : 00 - 15 - ID - 00 - 30 - 52 (each device has different address)	
- IP Address : 192. 168 . 0 . 50	
- Subnet mask : 255 255 . 255 . 0	
- Gateway : 192 168 . 0 . 1	

Step 1-Reference.

Details	Contents
MAC	Physical official address in the network.
IP Address	Setup the IP address that TOP receives in the network.
Subnet mask	An address that divides the network ID and host ID regarding of IP address.
Gateway	An address that connects a network to another network.

4.3 Communication diagnosis

- TOP - Confirming interface setting condition between external devices
- Move to Menu by clicking the top side of LCD screen as resetting the power of TOP.
- [Main Menu >Communication setting] Confirm if detail in number 20~24 is identical to the setup information of "■Setup exercise 1".
- PLC Setup > Click the button in "Communication diagnosis" of TOP Ethernet.
- Diagnosis dialog box will pop up on the screen, you can judge by following informations that are shown on box no. 3 section.

OK!	Communication setting succeeded
Time Out Error!	Communication setting error - Error in the setting situation of Cable and TOP / External device (reference : Communication Diagnosis sheet)

■ Communication Diagnosis Sheet

- Please refer to the information below if you have a problem between external devices and communication connection.

Details	Contents				Confirm			
TOP	Version Information	xDesignerPlus :	O.S :					
	Name of Driver					OK	NG	
	External device information (xDesignerPlus Project setting)	IP Address					OK	NG
		Subnet mask					OK	NG
		Gateway					OK	NG
	TOP Information (Main Device Menu Setting)	Protocol	UDP/IP	TCP/IP		OK	NG	
		IP Address					OK	NG
		Subnet mask					OK	NG
		Gateway					OK	NG
	Other specified setting info					OK	NG	
System configuration	System Connection Method	1:1	1:N	N:1	OK	NG		
	Name of cable (Hub usage)	Direct (Use Hub)		Cross (No Hub)	OK	NG		
External device	Name of CPU					OK	NG	
	Name of communication device					OK	NG	
	Protocol(mode)					OK	NG	
	Other specified setting info					OK	NG	
	IP Address	(Local)	(Destination)		OK	NG		
	Port number	(Local)	(Destination)		OK	NG		
	Subnet mask					OK	NG	
	Gateway					OK	NG	
Address range confirm (other docs)					OK	NG		

5. Available address

The available address of device are as below.

Device(address) range might be different according to series/type of CPU. TOP Series are capable of supporting maximum address range which is available in external Device.

Be careful get out of address range.

Device	Bit Address	Word Address	Double Word Address	32 Bit
Input Relay	IW000.00.0.00 – IW127.15.3.15	IW000.00.0 – IW127.15.3	–	L/H ^{*1)}
Output Relay	QW000.00.0.00 – QW127.15.3.15	QW000.00.0 – QW127.15.3	–	
R Memory	RW00000.00 – RW32768.15	RW00000 – RW32768	–	
W Memory	WW00000.00 – WW65535.15	WW00000 – WW65535	–	
M Memory	MW000000.00 – MW131071.15	MW000000 – MW131071	MD000000 – MD131070	
	MX0000000 – MX2097136			

*1) Low 16BIT of 32BIT data is saved address input by touch program, high 16Bit of 32BIT data is saved next address input by touch program.

(Ex) If you input [12345678] of hex 32bit data at address [D00100], save as below.

Item	32BIT	16BIT	
	address	D00100	D00101
Input data(Hex)	12345678	5678	1234