

# Seorim Automation Technology

## PMC3000 Series

### Computer Link Driver

---

Supported version

TOP Design Studio

V1.0 or higher



## CONTENTS

---

We want to thank our customers who use the Touch Operation Panel.

### **1. System configuration** [Page 2](#)

Describes the devices required for connection, the setting of each device, cables, and configurable systems.

---

### **2. External device selection** [Page 3](#)

Select a TOP model and an external device.

---

### **3. TOP communication setting** [Page 4](#)

Describes how to set the TOP communication.

---

### **4. External device setting** [Page 9](#)

Describes how to set up communication for external devices.

---

### **5. Cable table** [Page 10](#)

Describes the cable specifications required for connection.

---

### **6. Supported addresses** [Page 11](#)

Refer to this section to check the addresses which can communicate with an external device.

---

# 1. System configuration

The system configuration of TOP and "Seorim Automation Technology : PMC3000 Series Computer Link" is as follows:

| Series                       | CPU     | Link I/F | Communication method | System setting   | Cable                              |
|------------------------------|---------|----------|----------------------|--|------------------------------------|
| Seorim Automation Technology | PMC3000 | CN5      | RS-422 ( 4 wire )    | <a href="#">3. TOP communication setting</a><br><a href="#">4.1. External device setting 1</a> | <a href="#">5.1. Cable table 1</a> |

## ■ Connection configuration

- 1:1 connection (one MASTER and one TOP) connection



- 1:N (one TOP and multiple external devices) connection – configuration which is possible in RS422/485 communication.

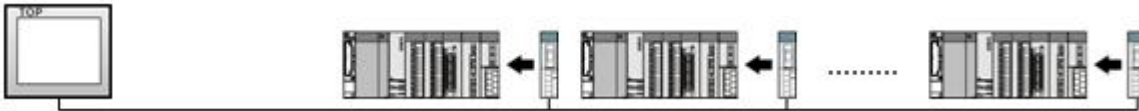

## 2. External device selection

- Select a TOP model and a port, and then select an external device.

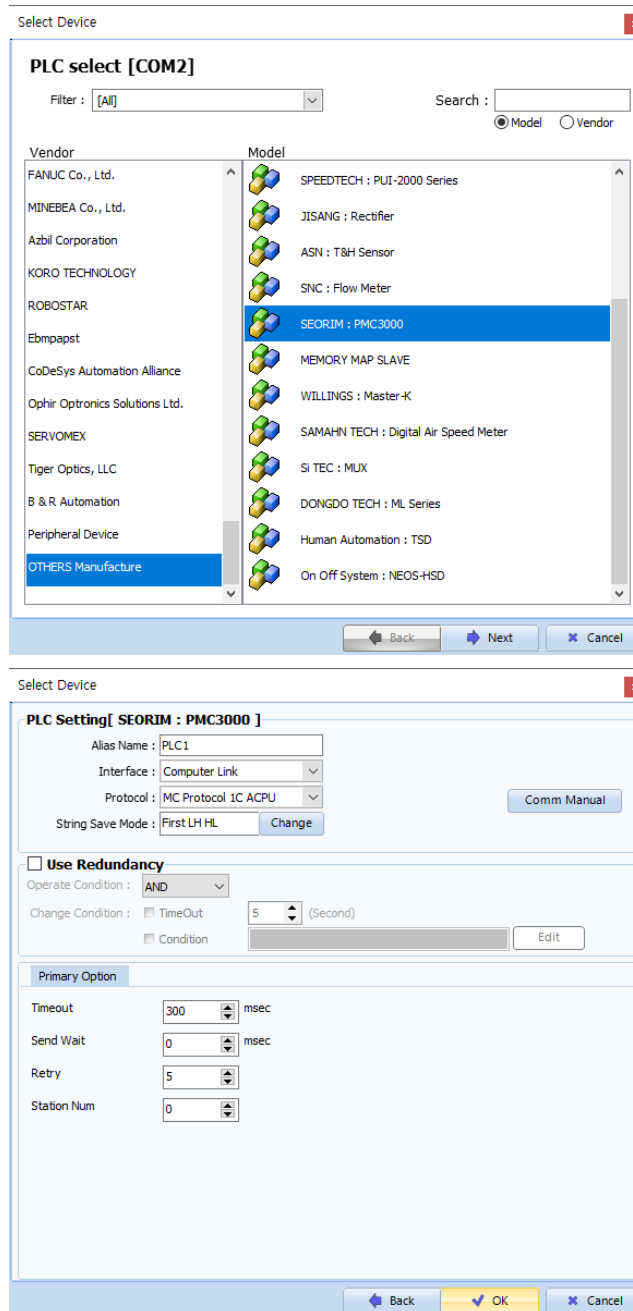

| Settings        |               | Contents  |       |           |          |         |               |
|-----------------|---------------|---|-------|-----------|----------|---------|---------------|
| TOP             | Model         | Check the TOP display and process to select the touch model.  |       |           |          |         |               |
| External device | Vendor        | Select the vendor of the external device to be connected to TOP.<br>Select "OTHERS".  |       |           |          |         |               |
|                 | PLC           | Select an external device to connect to TOP.<br><table border="1" style="width: 100%; border-collapse: collapse;"> <thead> <tr> <th>Model</th> <th>Interface</th> <th>Protocol</th> </tr> </thead> <tbody> <tr> <td>PMC3000</td> <td>Computer Link</td> <td>MC Protocol 1C ACPU</td> </tr> </tbody> </table> <p><b>Supported Protocol</b></p> <p>MC Protocol 1C Format 1</p> <p>Please check the system configuration in Chapter 1 to see if the external device you want to connect is a model whose system can be configured.</p> | Model | Interface | Protocol | PMC3000 | Computer Link |
| Model           | Interface     | Protocol  |       |           |          |         |               |
| PMC3000         | Computer Link | MC Protocol 1C ACPU   |       |           |          |         |               |

### 3. TOP communication setting

The communication can be set in TOP Design Studio or TOP main menu. The communication should be set in the same way as that of the external device.

#### 3.1 Communication setting in TOP Design Studio

##### (1) Communication interface setting

■ [Project > Project Property > TOP Setting] → [Project Option > "Use HMI Setup" Check > Edit > Serial]

– Set the TOP communication interface in TOP Design Studio.

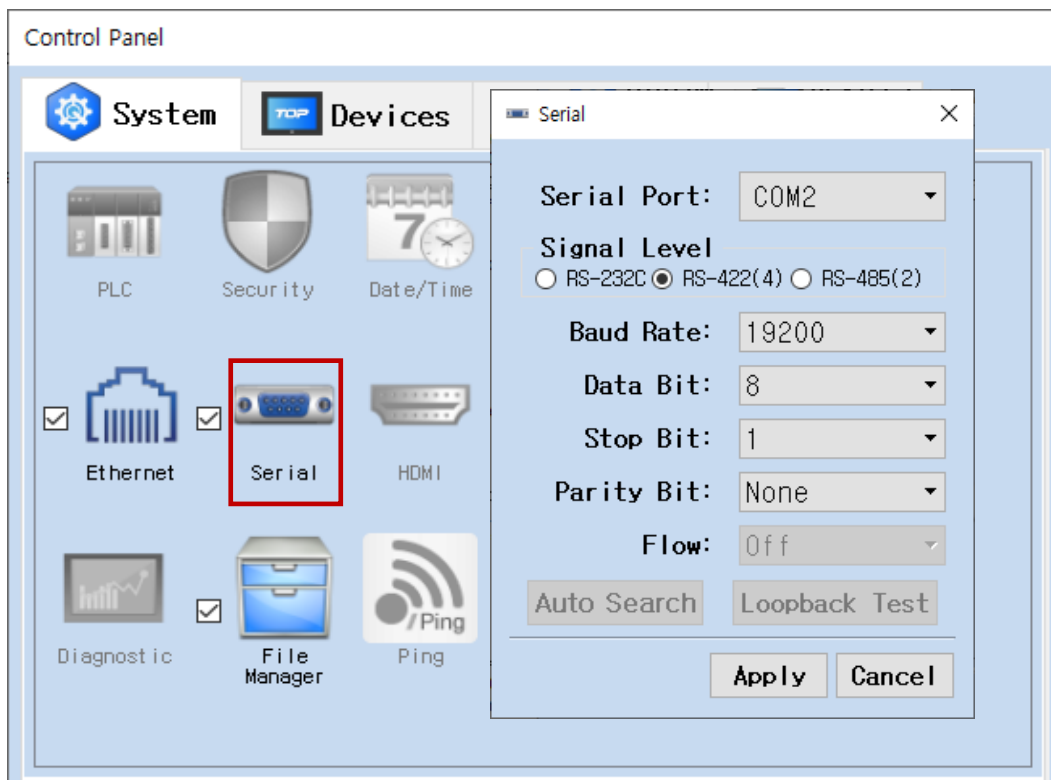
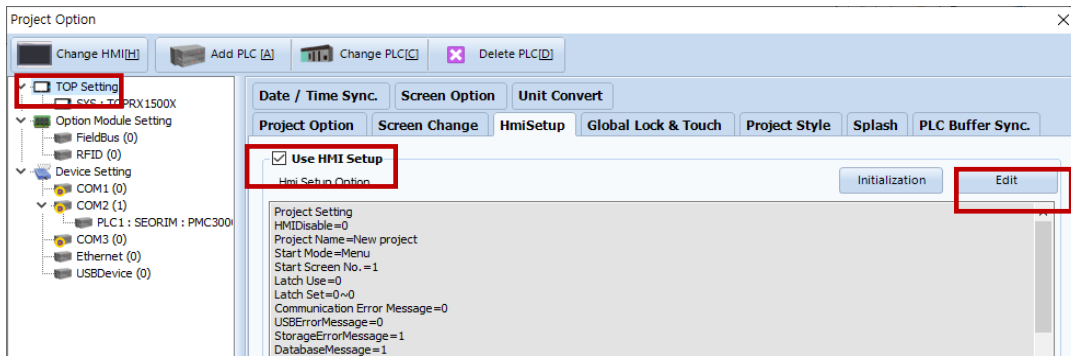

| Items               | TOP    | External device | Remarks |
|---------------------|--------|-----------------|---------|
| Signal Level (port) | RS-422 | RS-422          |         |
| Baud Rate           | 19200  |                 |         |
| Data Bit            | 8      |                 |         |
| Stop Bit            | 1      |                 |         |
| Parity Bit          | None.  |                 |         |

\* The above settings are examples recommended by the company.

| Items        | Description   |
|--------------|---|
| Signal Level | Select the serial communication method between the TOP and an external device.                  |
| Baud Rate    | Select the serial communication speed between the TOP and an external device.                   |
| Data Bit     | Select the serial communication data bit between the TOP and an external device.                |
| Stop Bit     | Select the serial communication stop bit between the TOP and an external device.                |
| Parity Bit   | Select the serial communication parity bit check method between the TOP and an external device. |

## (2) Communication option setting

■ [Project > Project Property > Device Setting > COM > "PLC1 : SEORIM PMC3000"]

– Set the options of the Seorim Automation Technology : PMC3000 Series Computer Link communication driver in TOP Design Studio.

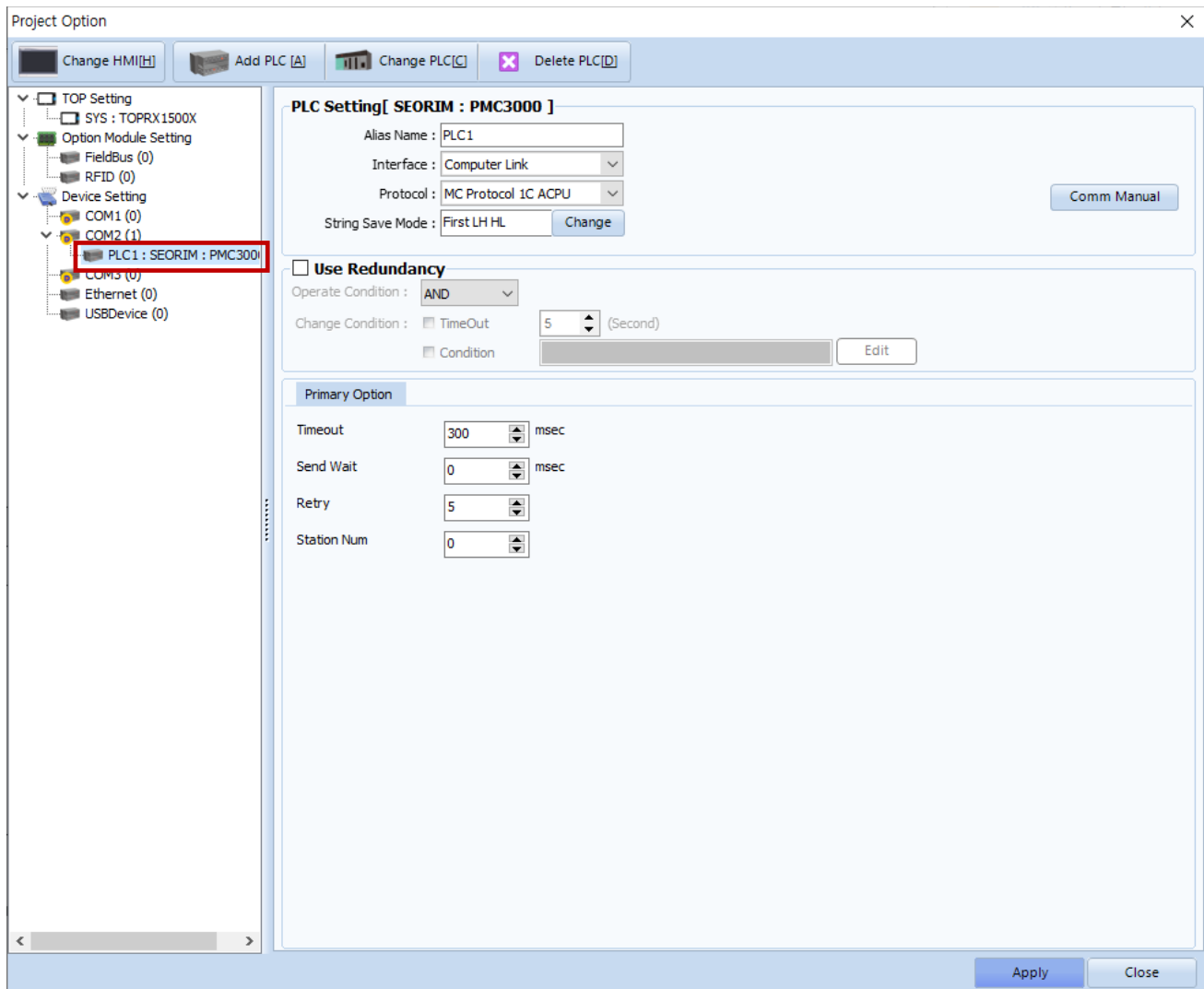

| Items         | Settings  | Remarks  |
|---------------|---|--|
| Interface     | Select "Computer Link".   | <a href="#">Refer to "2. External device selection".</a> |
| Protocol      | Select "PC Link".   |  |
| TimeOut (ms)  | Set the time for the TOP to wait for a response from an external device.  |  |
| SendWait (ms) | Set the waiting time between TOP's receiving a response from an external device and sending the next command request. |  |
| Station Num   | Enter the prefix of an external device.   |  |

### 3.2. Communication setting in TOP

\* This is a setting method when "Use HMI Setup" in the setting items in "3.1 TOP Design Studio" is not checked.

- Touch the top of the TOP screen and drag it down. Touch "EXIT" in the pop-up window to go to the main screen.

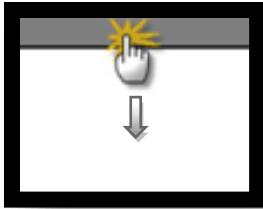

#### (1) Communication interface setting

- [Main Screen > Control Panel > Serial]

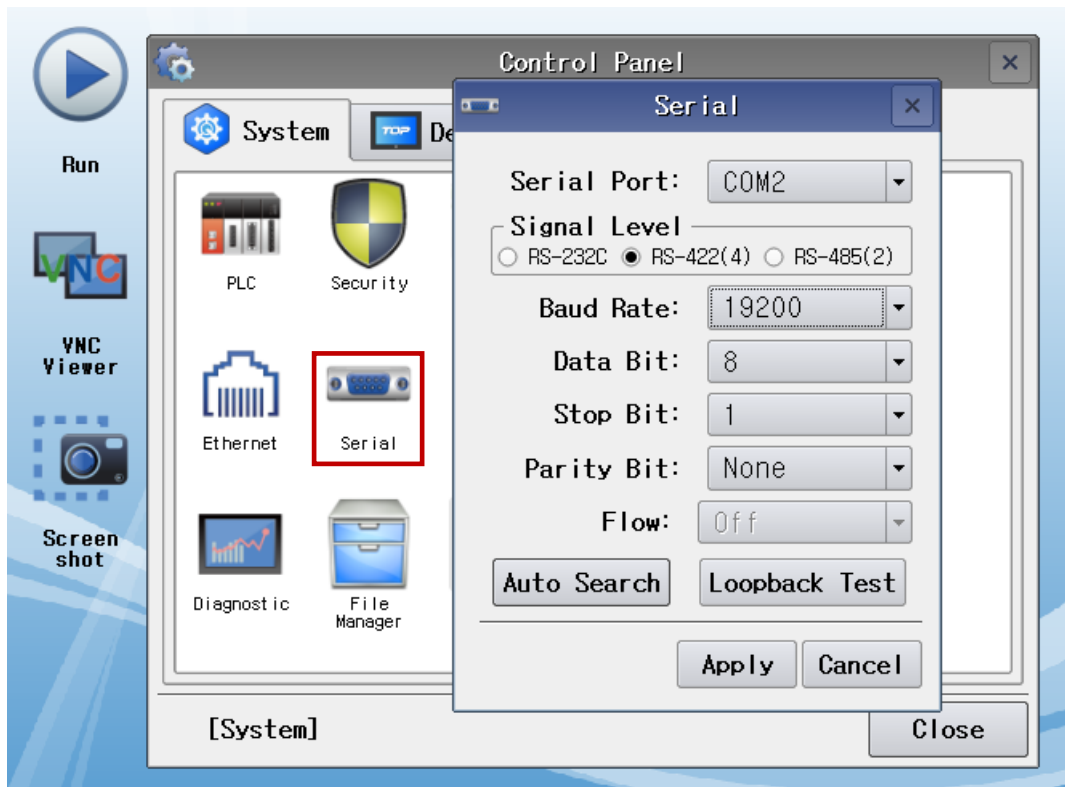

| Items               | TOP    | External device | Remarks |
|---------------------|--------|-----------------|---------|
| Signal Level (port) | RS-422 | RS-422          |         |
| Baud Rate           | 19200  |                 |         |
| Data Bit            | 8      |                 |         |
| Stop Bit            | 1      |                 |         |
| Parity Bit          | None.  |                 |         |

\* The above settings are setting examples recommended by the company.

| Items        | Description   |
|--------------|---|
| Signal Level | Select the serial communication method between the TOP and an external device.                  |
| Baud Rate    | Select the serial communication speed between the TOP and an external device.                   |
| Data Bit     | Select the serial communication data bit between the TOP and an external device.                |
| Stop Bit     | Select the serial communication stop bit between the TOP and an external device.                |
| Parity Bit   | Select the serial communication parity bit check method between the TOP and an external device. |

(2) Communication option setting

■ [Main Screen > Control Panel > PLC]

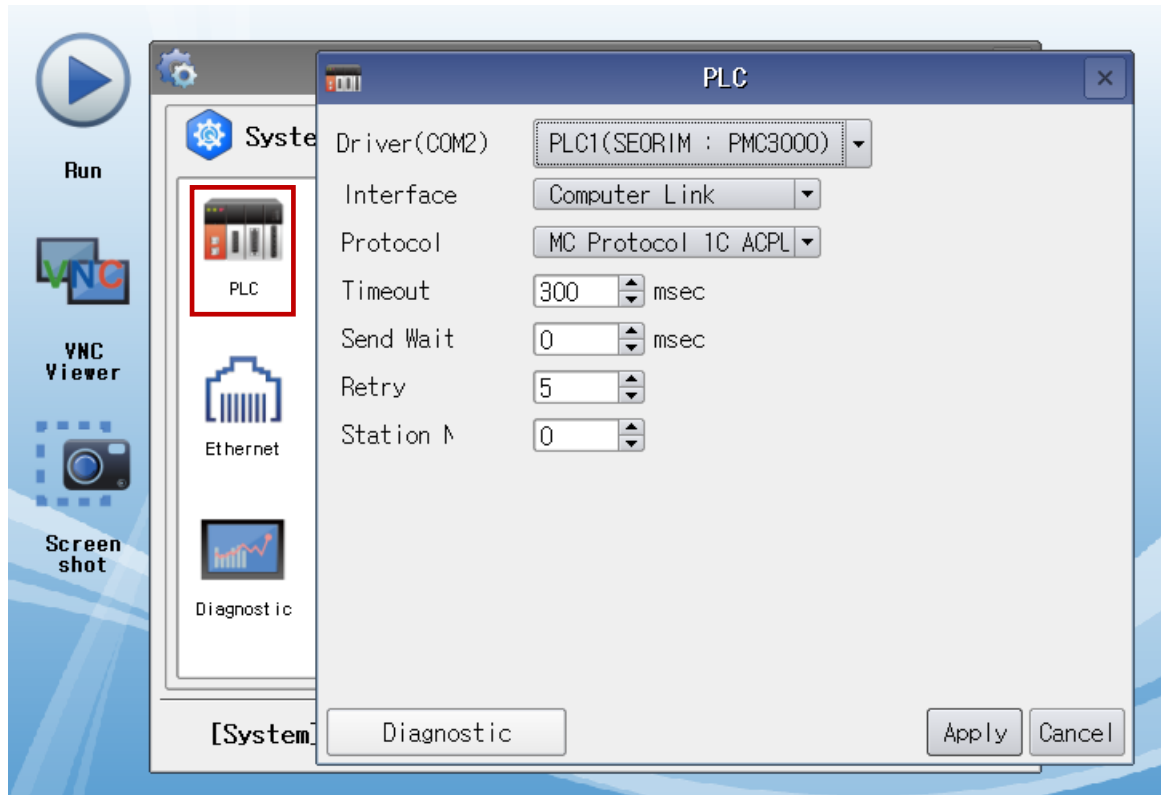

| Items         | Settings  | Remarks  |
|---------------|---|--|
| Interface     | Select "Computer Link".   | <a href="#">Refer to "2. External device selection".</a> |
| Protocol      | Select "pc link".   |  |
| TimeOut (ms)  | Set the time for the TOP to wait for a response from an external device.  |  |
| SendWait (ms) | Set the waiting time between TOP's receiving a response from an external device and sending the next command request. |  |
| Station Num   | Enter the prefix of an external device.   |  |

### 3.3 Communication diagnostics

- Check the interface setting status between the TOP and an external device.
  - Touch the top of the TOP screen and drag it down. Touch "EXIT" in the pop-up window to go to the main screen.
  - Check if the COM port settings you want to use in [Control Panel > Serial] are the same as those of the external device.
  
- Diagnosis of whether the port communication is normal or not
  - Touch "Communication diagnostics" in [Control Panel > PLC].
  - The Diagnostics dialog box pops up on the screen and determines the diagnostic status.

|                       |  |
|-----------------------|--|
| <b>OK</b>             | <b>Communication setting normal</b>  |
| <b>Time Out Error</b> | <b>Communication setting abnormal</b><br>- Check the cable, TOP, and external device setting status. <b>(Reference: Communication diagnostics sheet)</b> |

■ Communication diagnostics sheet

- If there is a problem with the communication connection with an external terminal, please check the settings in the sheet below.

| Items                | Contents                              | Check                     |   | Remarks  |    |
|----------------------|---------------------------------------|---------------------------|---|--|----|
| System configuration | How to connect the system             | OK                        | NG  | <a href="#">1. System configuration</a>  |    |
|                      | Connection cable name                 | OK                        | NG  |  |    |
| TOP                  | Version information                   | OK                        | NG  | <a href="#">2. External device selection</a><br><a href="#">3. Communication setting</a> |    |
|                      | Port in use                           | OK                        | NG  |  |    |
|                      | Driver name                           | OK                        | NG  |  |    |
|                      | Other detailed settings               | OK                        | NG  |  |    |
|                      | Relative prefix                       | Project setting           | OK  |  | NG |
|                      |                                       | Communication diagnostics | OK  |  | NG |
|                      | Serial Parameter                      | Transmission Speed        | OK  |  | NG |
| Data Bit             |                                       | OK                        | NG  |  |    |
| Stop Bit             |                                       | OK                        | NG  |  |    |
| Parity Bit           |                                       | OK                        | NG  |  |    |
| External device      | CPU name                              | OK                        | NG  | <a href="#">4. External device setting</a>   |    |
|                      | Communication port name (module name) | OK                        | NG  |  |    |
|                      | Protocol (mode)                       | OK                        | NG  |  |    |
|                      | Setup Prefix                          | OK                        | NG  |  |    |
|                      | Other detailed settings               | OK                        | NG  |  |    |
|                      | Serial Parameter                      | Transmission Speed        | OK  |  | NG |
|                      |                                       | Data Bit                  | OK  |  | NG |
|                      |                                       | Stop Bit                  | OK  |  | NG |
| Parity Bit           |                                       | OK                        | NG  |  |    |
| Check address range  | OK                                    | NG                        | <a href="#">6. Supported addresses</a><br>(For details, please refer to the PLC vendor's manual.) |  |    |



## 4. External device setting

---

For more detailed setting method than that described, refer to the PLC user manual.

## 5. Cable table

This chapter introduces a cable diagram for normal communication between the TOP and the corresponding device.

(The cable diagram described in this section may differ from the recommendations of "Seorim Automation Technology : PMC3000 Series Computer Link")

### 5.1. Cable table (PMC3000)

#### ■ RS-422 (1:1 connection)

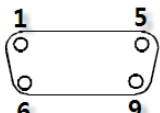
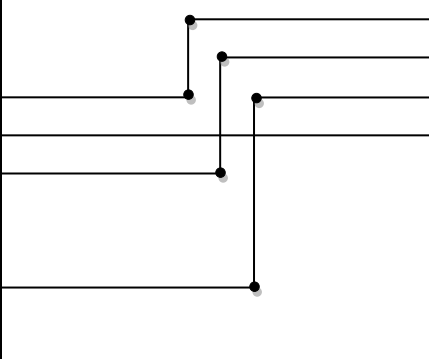
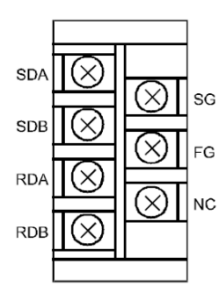
| TOP  |             |            | Cable connection   | External device            |   |
|--|-------------|------------|--|----------------------------|---|
| Pin arrangement* <b>Note 1)</b>  | Signal name | Pin number |  | Signal name                | Pin arrangement   |
|  <p>Based on communication cable connector front, D-SUB 9 Pin male (male, convex)</p> | RDA         | 1          |  | TX+(6)                     |  |
|  |             | 2          |  | TX-(7)                     |   |
|  |             | 3          |  | RX+(4)                     |   |
|  | RDB         | 4          |  | RX-(5)                     |   |
|  | SG          | 5          |  | SG                         |   |
|  | SDA         | 6          |  | Terminating resistance (2) |   |
|  |             | 7          |  | Terminating resistance (1) |   |
|  |             | 8          |  |                            |   |
|  | SDB         | 9          |  |                            |   |

\***Note 1)** The pin arrangement is as seen from the connecting side of the cable connection connector.

#### ■ RS-422 (1:N connection) – Refer to 1:1 connection to connect in the following way.

| TOP         | Cable connection and signal direction | External device | Cable connection and signal direction | External device |
|-------------|---------------------------------------|-----------------|---------------------------------------|-----------------|
| Signal name |                                       | Signal name     |                                       | Signal name     |
| RDA         |                                       | SDA             |                                       | SDA             |
| RDB         |                                       | SDB             |                                       | SDB             |
| SDA         |                                       | RDA             |                                       | RDA             |
| SDB         |                                       | RDB             |                                       | RDB             |
| SG          |                                       | SG              |                                       | SG              |

## 6. Supported addresses

The devices available in TOP are as follows:

The device range (address) may differ depending on the CPU module series/type. The TOP series supports the maximum address range used by the external device series. Please refer to each CPU module user manual and be take caution to not deviate from the address range supported by the device you want to use.

| Type                  | Remarks | Bit-designated address | Word-designated address |
|-----------------------|---------|------------------------|-------------------------|
| Input                 | Bit     | X0000 – X1FFF          | X0000 – X1FF0           |
| Output                | Bit     | Y0000 – Y1FFF          | Y0000 – Y1FF0           |
| Special relay         | Bit     | F0000 – F2047          | F0000 – F2032           |
| LATCH relay           | Bit     | L0000 – L8191          | L0000 – L8176           |
| Internal relay        | Bit     | M0000 – M8191          | M0000 – M8176           |
| Special relay         | Bit     | M9000 - M9255          | M9000 – M9240           |
| Timer-Current value   | Word    | TN000.00 – TN2047.15   | TN000 – TN2047          |
| Counter-Current value | Word    | CN000.00 – CN2047.15   | CN000 – CN2047          |
| LINK relay            | Bit     | B0000 – B1FFF          | B0000 – B1FFF           |
| LINK register         | Word    | W0000.0 – W1FFF.F      | W0000 – W1FFF           |
| Data register         | Word    | D0000.0 – D8191.15     | D0000 – D8191           |
| Special register      | Word    | D9000.0 - D9255.15     | D9000 - D9255           |