

SANGJI Precision

SJ Series

SJD RS-232C

Supported version TOP Design Studio V1.4.2 or higher



CONTENTS

We want to thank our customers who use the Touch Operation Panel.

1. System configuration [Page 2](#)

Describes the devices required for connection, the setting of each device, cables, and configurable systems.

2. External device selection [Page 3](#)

Select a TOP model and an external device.

3. TOP communication setting [Page 4](#)

Describes how to set the TOP communication.

4. External device setting [Page 9](#)

Describes how to set up communication for external devices.

5. Cable table [Page 10](#)

Describes the cable specifications required for connection.

6. Supported addresses [Page 11](#)

Refer to this section to check the addresses which can communicate with an external device.

1. System configuration

The system configuration of TOP-R and "Sangji Precision Co., Ltd. – SJD RS232C" is as follows:

Series	CPU	Link I/F	Communication method	System setting	Cable
SJ Series	SJD RS232C	Port on CPU unit	RS-232C	3.1 Settings example	5.1. Cable table

■ Connection configuration

- 1:1 (one TOP and one external device) connection – configuration which is possible in RS232C communication.



2. External device selection

- Select a TOP-R model and a port, and then select an external device.

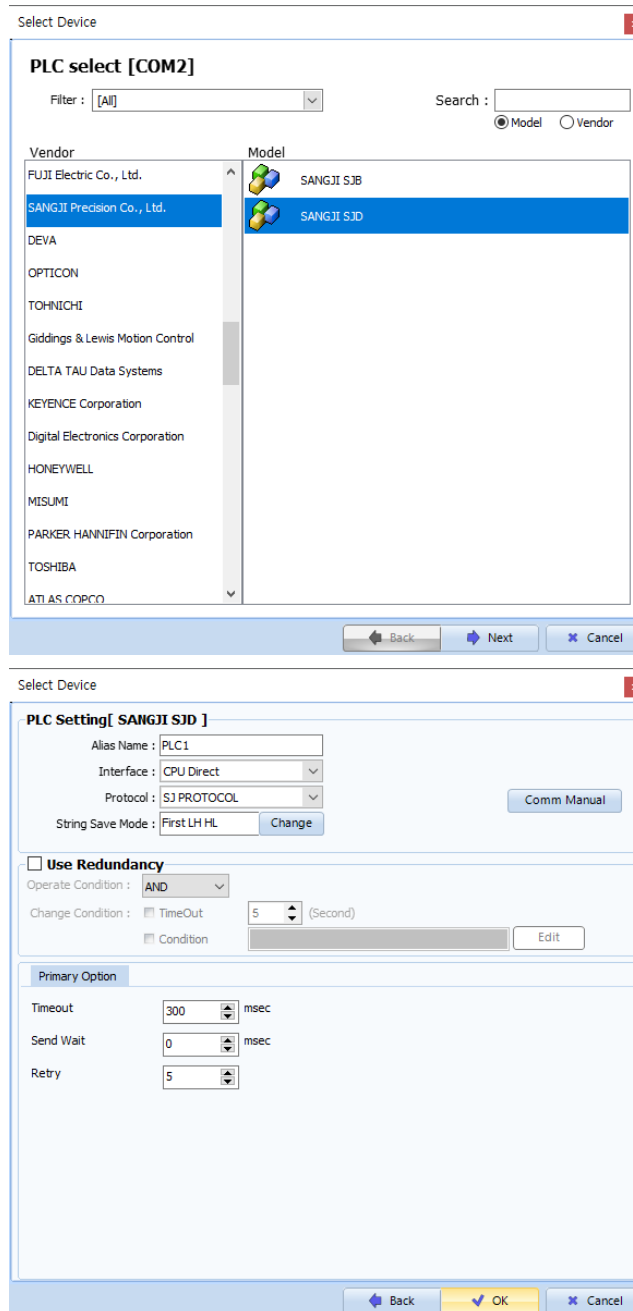

Settings		Contents					
TOP-R	Model	Check the TOP-R display and process to select the touch model.					
External device	Vendor	Select the vendor of the external device to be connected to TOP-R. Select "Sangji Precision Co., Ltd."					
	PLC	Select an external device to connect to TOP-R. <table border="1" style="width: 100%; border-collapse: collapse;"> <thead> <tr> <th style="background-color: black; color: white;">Model</th> <th style="background-color: black; color: white;">Interface</th> <th style="background-color: black; color: white;">Protocol</th> </tr> </thead> <tbody> <tr> <td>SJD_RS232</td> <td>CPU Direct</td> <td>Sj protocol</td> </tr> </tbody> </table> <p>Please check the system configuration in Chapter 1 to see if the external device you want to connect is a model whose system can be configured.</p>	Model	Interface	Protocol	SJD_RS232	CPU Direct
Model	Interface	Protocol					
SJD_RS232	CPU Direct	Sj protocol					

3. TOP-R Communication setting

The communication can be set in TOP Design Studio or TOP-R main menu. The communication should be set in the same way as that of the external device.

3.1 Communication setting in TOP Design Studio

(1) Communication interface setting

- [Project > Project Property > TOP Setting] → [Project Option > "Use HMI Setup" Check > Edit > Serial]
- Set the TOP-R communication interface in TOP Design Studio.

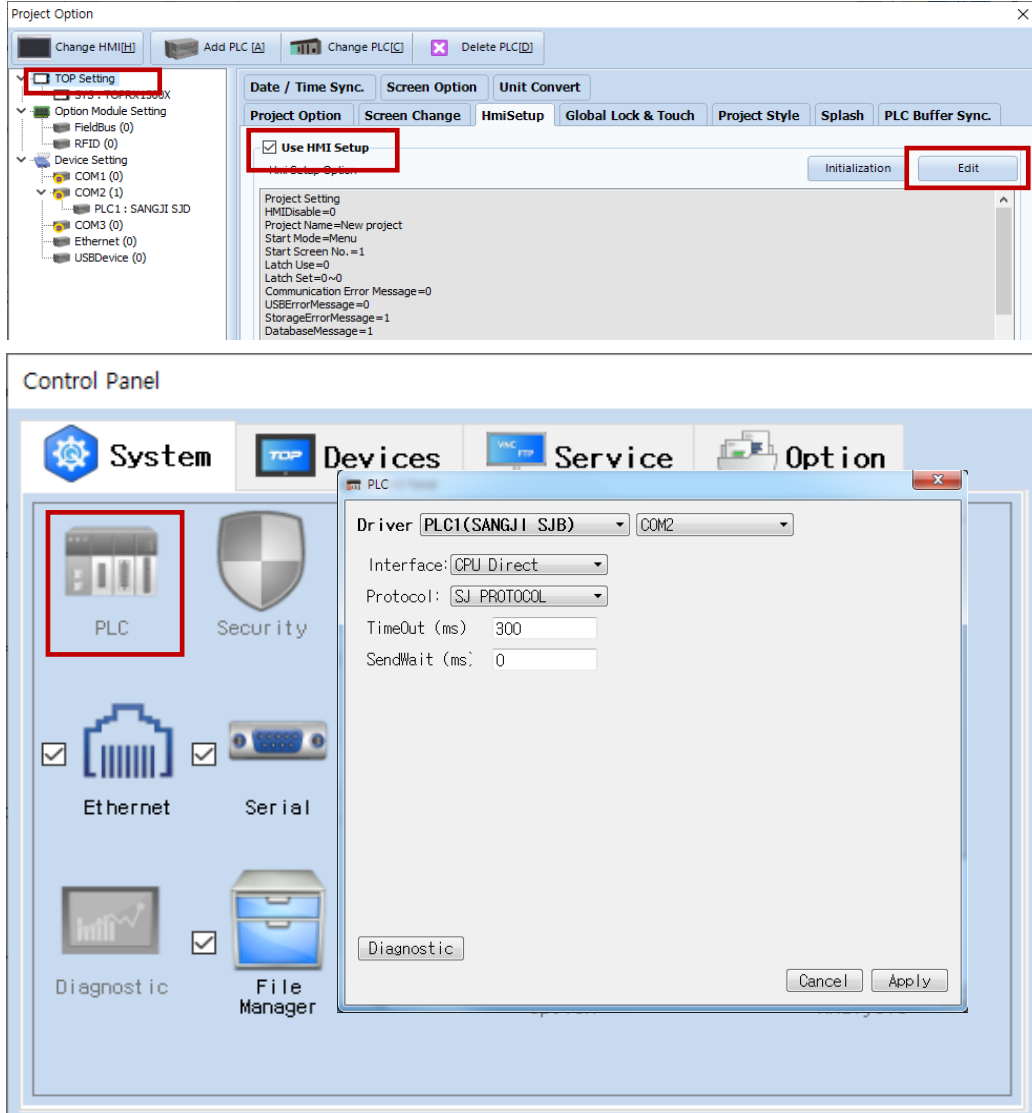

Items	TOP-R	External device	Remarks
Signal Level (port)	RS-232C	RS-232C	
Baud Rate	9600		
Data Bit	8		
Stop Bit	1		
Parity Bit	NONE		

* The above settings are examples recommended by the company.

Items	Description
Signal Level	Select the serial communication method between the TOP-R and an external device.
Baud Rate	Select the serial communication speed between the TOP-R and an external device.
Data Bit	Select the serial communication data bit between the TOP-R and an external device.
Stop Bit	Select the serial communication stop bit between the TOP-R and an external device.
Parity Bit	Select the serial communication parity bit check method between the TOP-R and an external device.

(2) Communication option setting

- [Project > Project Property > Device Setting > COM > "PLC1: SANGJI SJD"]
 – Set the options of the FP Series Computer Link communication driver in TOP Design Studio.

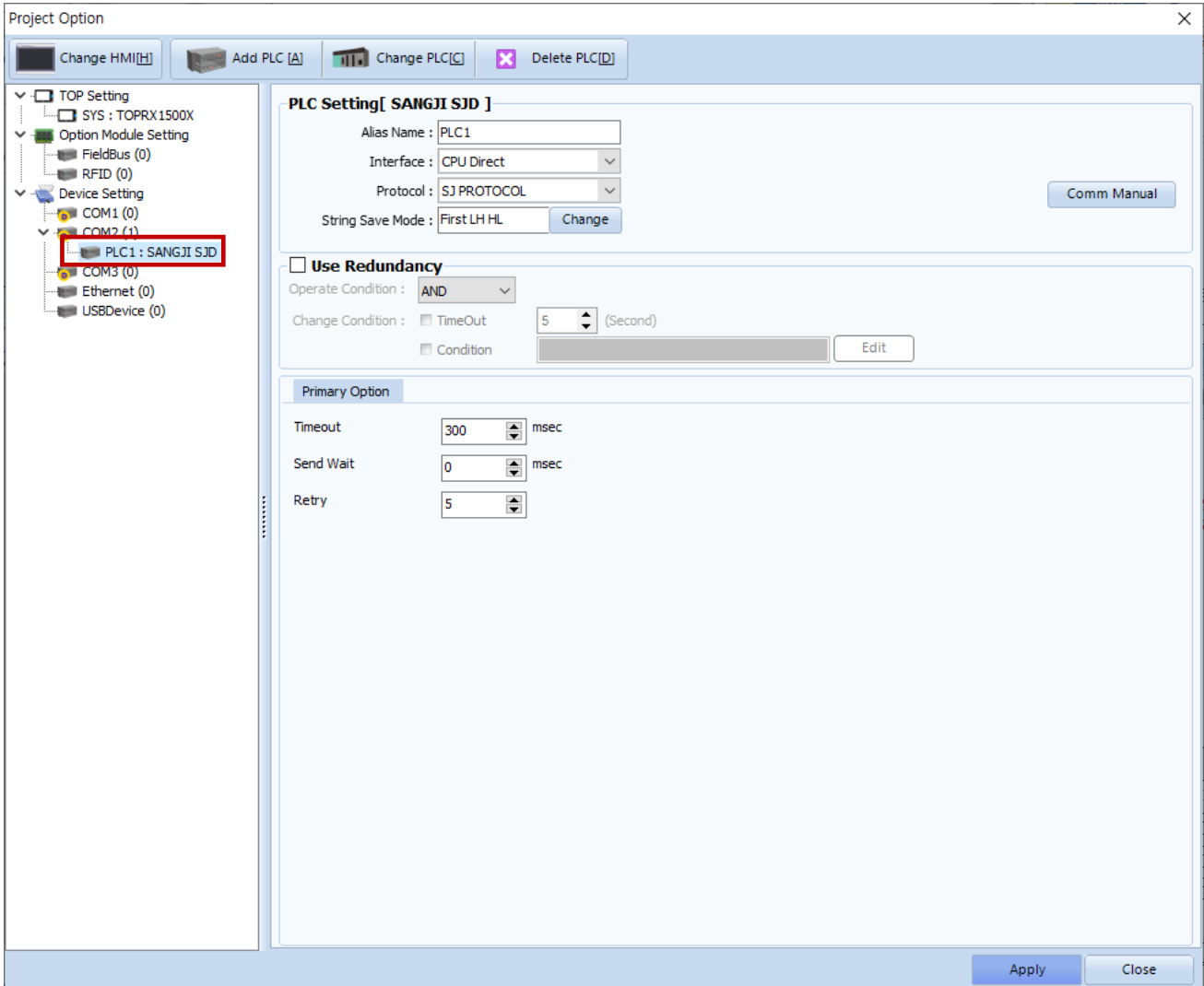

Items	Settings	Remarks
Interface	Select "CPU Direct".	Refer to "2. External device selection".
Protocol	Select the serial communication protocol between the TOP-R and an external device.	
TimeOut (ms)	Set the time for the TOP-R to wait for a response from an external device.	
SendWait (ms)	Set the waiting time between TOP-R's receiving a response from an external device and sending the next command request.	

3.2. Communication setting in TOP-R

* This is a setting method when "Use HMI Setup" in the setting items in "3.1 TOP Design Studio" is not checked.

- Touch the top of the TOP-R screen and drag it down. Touch "EXIT" in the pop-up window to go to the main screen.



(1) Communication interface setting

- [Main Screen > Control Panel > Serial]

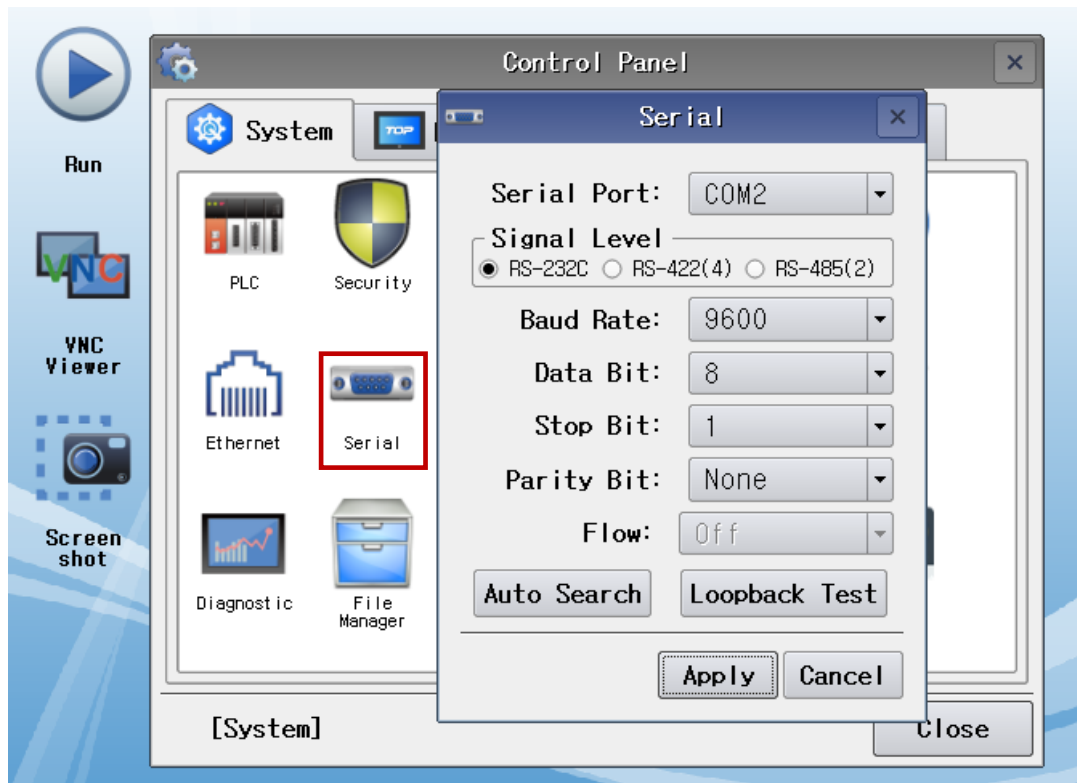

Items	TOP-R	External device	Remarks
Signal Level (port)	RS-232C	RS-232C	
Baud Rate	9600		
Data Bit	8		
Stop Bit	1		
Parity Bit	none		

* The above settings are setting examples recommended by the company.

Items	Description
Signal Level	Select the serial communication method between the TOP-R and an external device.
Baud Rate	Select the serial communication speed between the TOP-R and an external device.
Data Bit	Select the serial communication data bit between the TOP-R and an external device.
Stop Bit	Select the serial communication stop bit between the TOP-R and an external device.
Parity Bit	Select the serial communication parity bit check method between the TOP-R and an external device.

(2) Communication option setting

■ [Main Screen > Control Panel > PLC]

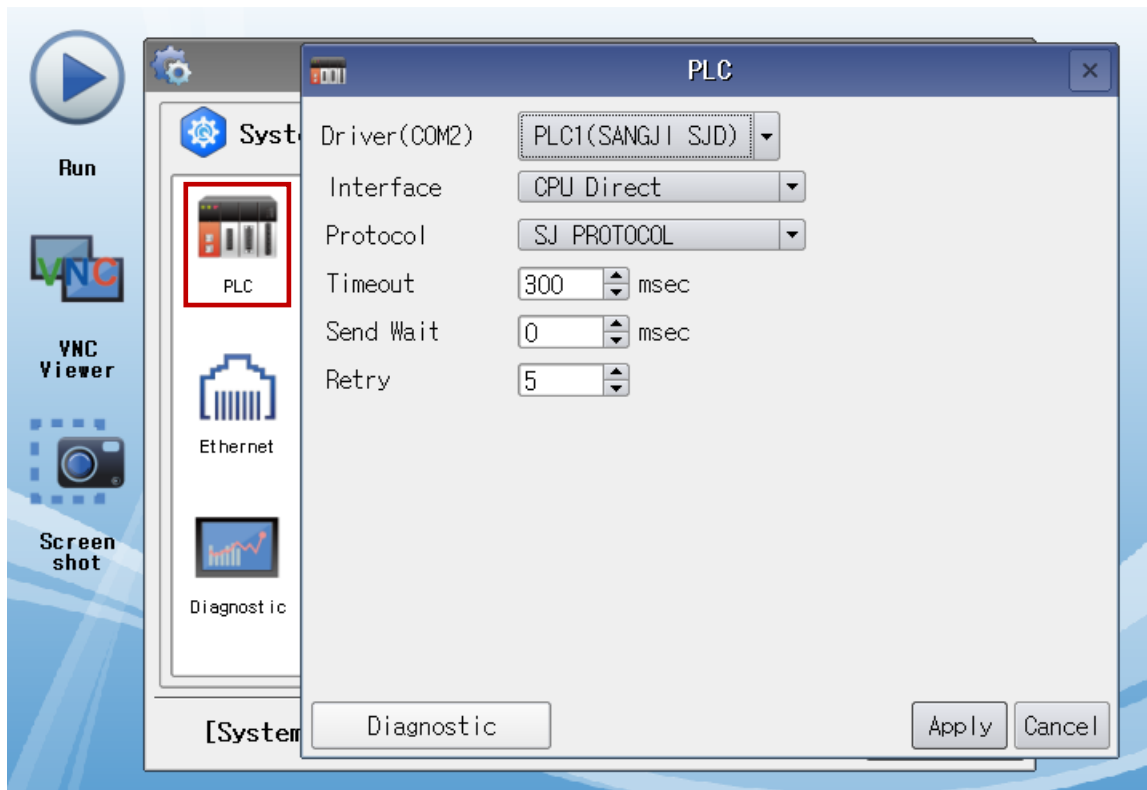

Items	Settings	Remarks
Interface	Select "Computer Link".	Refer to "2. External device selection".
Protocol	Select the serial communication protocol between the TOP-R and an external device.	
TimeOut (ms)	Set the time for the TOP-R to wait for a response from an external device.	
SendWait (ms)	Set the waiting time between TOP-R's receiving a response from an external device and sending the next command request.	

3.3 Communication diagnostics

- Check the interface setting status between the TOP-R and an external device.
 - Touch the top of the TOP-R screen and drag it down. Touch "EXIT" in the pop-up window to go to the main screen.
 - Check if the COM port settings you want to use in [Control Panel > Serial] are the same as those of the external device.

- Diagnosis of whether the port communication is normal or not
 - Touch "Communication diagnostics" in [Control Panel > PLC].
 - The Diagnostics dialog box pops up on the screen and determines the diagnostic status.

OK	Communication setting normal
Time Out Error	Communication setting abnormal
	- Check the cable, TOP-R, and external device setting status. (Reference: Communication diagnostics sheet)

- Communication diagnostics sheet
 - If there is a problem with the communication connection with an external terminal, please check the settings in the sheet below.

Items	Contents	Check		Remarks	
System configuration	How to connect the system	OK	NG	1. System configuration	
	Connection cable name	OK	NG		
TOP-R	Version information	OK	NG	2. External device selection 3. Communication setting	
	Port in use	OK	NG		
	Driver name	OK	NG		
	Other detailed settings	OK	NG		
	Relative prefix	Project setting	OK		NG
		Communication diagnostics	OK		NG
	Serial Parameter	Transmission Speed	OK		NG
		Data Bit	OK		NG
Stop Bit		OK	NG		
Parity Bit		OK	NG		
External device	CPU name	OK	NG	4. External device setting	
	Communication port name (module name)	OK	NG		
	Protocol (mode)	OK	NG		
	Setup Prefix	OK	NG		
	Other detailed settings	OK	NG		
	Serial Parameter	Transmission Speed	OK		NG
		Data Bit	OK		NG
		Stop Bit	OK		NG
Parity Bit		OK	NG		
Check address range	OK	NG	6. Supported addresses (For details, please refer to the PLC vendor's manual.)		

4. External device setting

Refer to the vendor's user manual to identically configure the communication settings of the external device to that of the TOP.

5. Cable table

This chapter introduces a cable diagram for normal communication between the TOP-R and the corresponding device.
 (The cable diagram described in this section may differ from the recommendations of "Sangji Precision Co., Ltd.")

5.1. Cable table 1

■ RS-232C (1:1 connection)

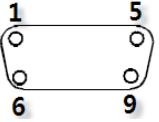
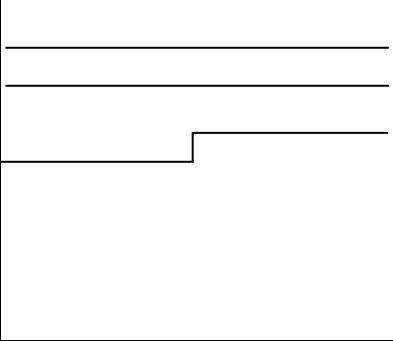
TOP			Cable connection	External device		
Pin arrangement* Note 1)	Signal name	Pin number		Pin number	Signal name	Pin arrangement* Note 1)
 <p>Based on communication cable connector front, D-SUB 9 Pin male (male, convex)</p>	CD	1		9	SG	
	RD	2		3	TXD	
	SD	3		6	RXD	
	DTR	4		5	SG	
	SG	5			DSR	
	DSR	6		7	CTS	
	RTS	7		8	RTS	
	CTS	8			-	
				9		

*[Note 1](#)) The pin arrangement is as seen from the connecting side of the cable connection connector.

6. Supported addresses

The devices available in TOP-R are as follows:

The device range (address) may differ depending on the CPU module series/type. The TOP series supports the maximum address range used by the external device series. Please refer to each CPU module user manual and be take caution to not deviate from the address range supported by the device you want to use.

Contents	Bit Address	Word Address	32 Bit	Remarks
M	0.0 – 799.31	0 – 799	O	
P	0.0 – 799.31	0 – 799	O	
ET	900.0 – 1024.31	900 – 1024	O	

< Error code summary >

The typical error codes are listed below.

Check the details of the error for each code.

Category	Error Code	Detail
1	[02]	Unknown command received
2	[03]	Unknown index value received
3	[05]	Unknown message received
4	[19]	Unknown command format
5	Other values	Miscellaneous error