

Tiger Optics, LLC

HALO Series

Serial Driver

Supported version

TOP Design Studio

V1.4.11.33 or higher



CONTENTS

We want to thank our customers who use the Touch Operation Panel.

1. System configuration [Page 2](#)

Describes connectable devices and network configurations.

2. External device selection [Page 3](#)

Select a TOP model and an external device.

3. TOP communication setting [Page 4](#)

Describes how to set the TOP communication.

4. External device setting [Page 10](#)

Describes how to set up communication for external devices.

5. Cable table [Page 11](#)

Describe the cable specifications required for connection.

6. Supported addresses [Page 12](#)

Refer to this section to check the data addresses which can communicate with an external device.

1. System configuration

The system configuration of TOP and Tiger Optics, LLC – HALO Series is as follows:

Series	Link I/F	Communication method	System setting	Cable
HALO KA HALO 3	Serial interface on rear panel	RS-232C RS-485	3. TOP communication setting 4. External device setting	5. Cable table

■ Connectable configuration

- 1:1 connection



2. External device selection

- Select a TOP model and a port, and then select an external device.

Settings		Contents					
TOP	Model	Check the display and process of TOP to select the touch model.					
External device	Vendor	Select the vendor of the external device to be connected to TOP. Select "Tiger Optics, LLC".					
	PLC	Select an external device to connect to TOP. <table border="1" style="width: 100%; border-collapse: collapse;"> <thead> <tr> <th style="background-color: black; color: white;">Model</th> <th style="background-color: black; color: white;">Interface</th> <th style="background-color: black; color: white;">Protocol</th> </tr> </thead> <tbody> <tr> <td>HALO Series</td> <td>Serial</td> <td>Remote Command</td> </tr> </tbody> </table> <p>Please check the system configuration in Chapter 1 to see if the external device you want to connect is a model whose system can be configured.</p>	Model	Interface	Protocol	HALO Series	Serial
Model	Interface	Protocol					
HALO Series	Serial	Remote Command					

3. TOP communication setting

The communication can be set in TOP Design Studio or TOP main menu. The communication should be set in the same way as that of the external device.

3.1 Communication setting in TOP Design Studio

(1) Communication interface setting

- [Project] → [Property] → [TOP Setting] → [HMI Setup] → [Use HMI Setup Check] → [Edit] → [Serial]
- Set the TOP communication interface in TOP Design Studio.

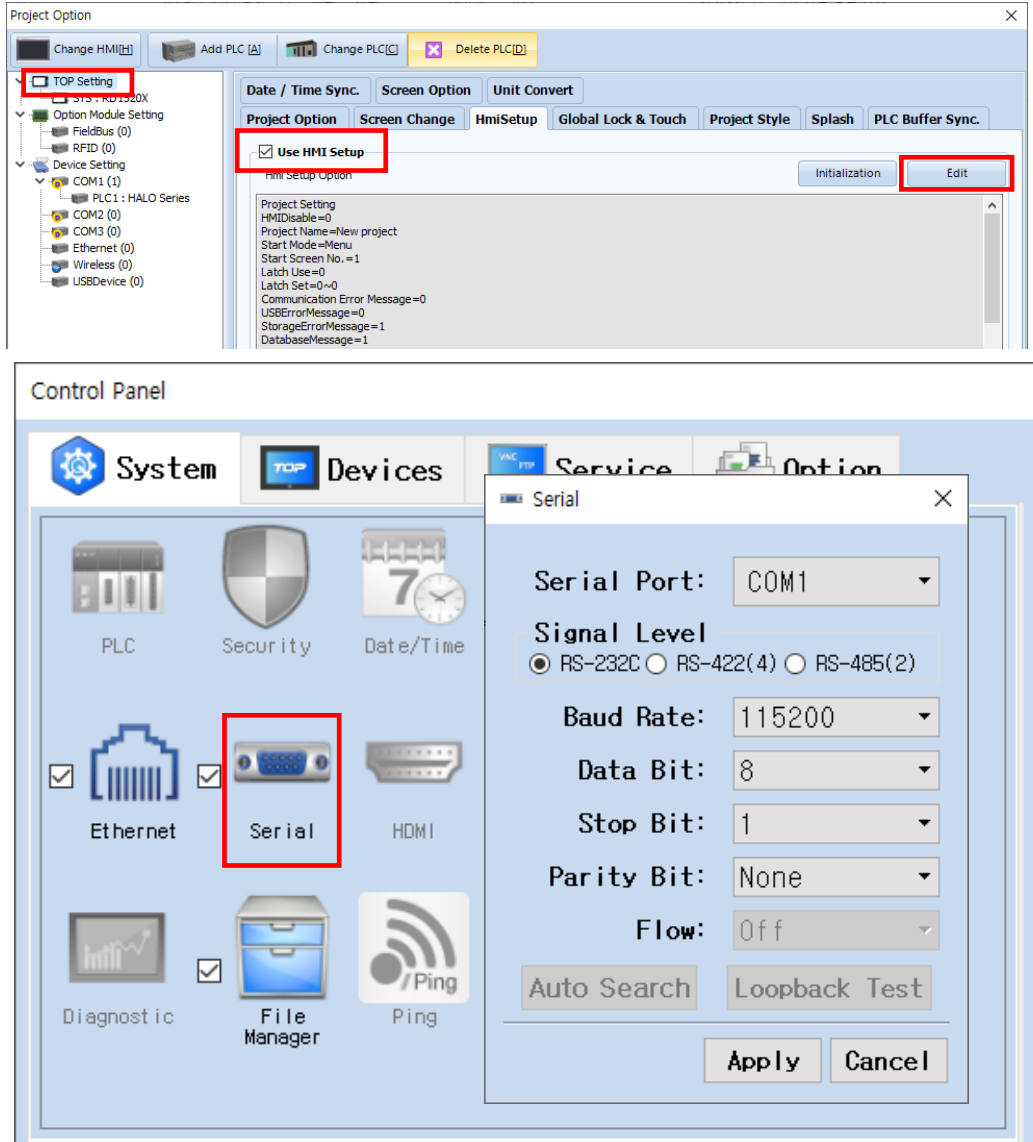

Items	TOP	External device	Remarks
Signal Level	RS-232C RS-485	RS-232C RS-485	
Baud Rate	115200		
Data Bit	8		
Stop Bit	1		
Parity Bit	None.		

* The above settings are examples recommended by the company.

Items	Description
Signal Level	Select the serial communication method between the TOP and an external device.
Baud Rate	Select the serial communication speed between the TOP and an external device.
Data Bit	Select the serial communication data bit between the TOP and an external device.
Stop Bit	Select the serial communication stop bit between the TOP and an external device.
Parity Bit	Select the serial communication parity bit check method between the TOP and an external device.

(2) Communication option setting

- [Project] → [Project Property] → [Device Setting > COM1 > HALO Series]
 - Set the options of the HALO Series communication driver in TOP Design Studio.

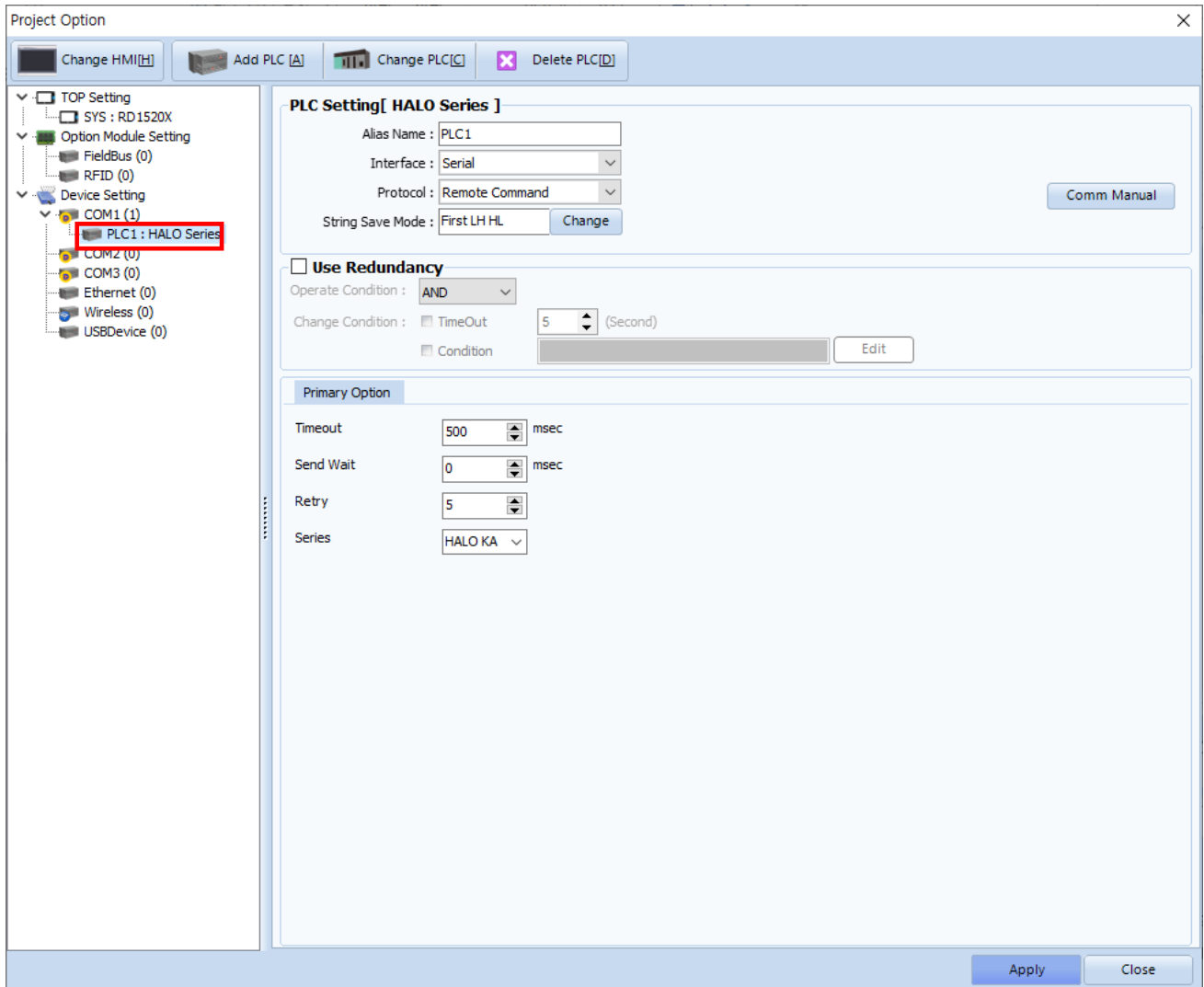

Items	Settings	Remarks
Interface	Select "Serial".	Refer to "2. External device selection".
Protocol	Select "Remote Command".	
Timeout	Set the time to wait for a response from an external device.	
Send Wait	Set the waiting time before sending a data request to an external device.	
Series	Select the series of the external device.	

3.2. Communication setting in TOP

* This is a setting method when "Use HMI Setup" in the setting items in "3.1 TOP Design Studio" is not checked.

■ Touch the top of the TOP screen and drag it down. Touch "EXIT" in the pop-up window to go to the main screen.

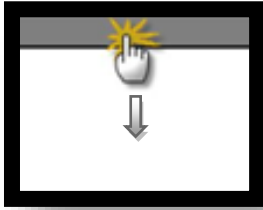

(1) Communication interface setting

■ [Control Panel] → [Serial]

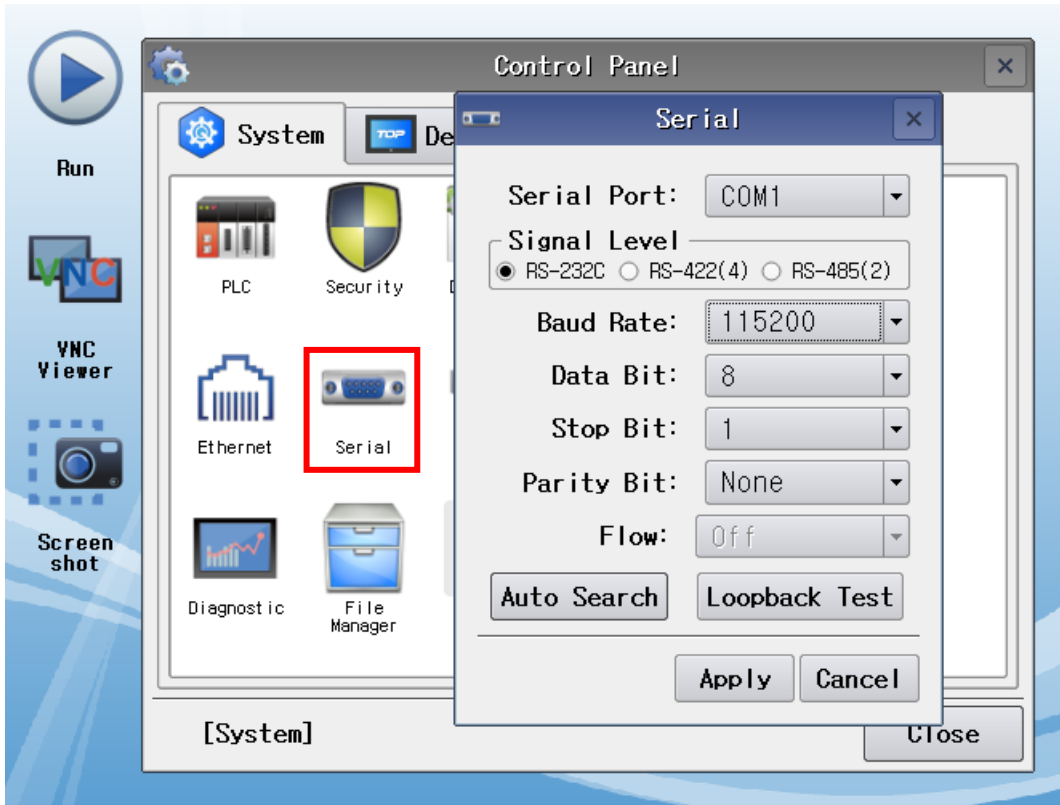

Items	TOP	External device	Remarks
Signal Level (port)	RS-232C	RS-232C	
	RS-485	RS-485	
Baud Rate	115200		
Data Bit	8		
Stop Bit	1		
Parity Bit	None.		

* The above settings are setting examples recommended by the company.

Items	Description
Signal Level	Select the serial communication method between the TOP and an external device.
Baud Rate	Select the serial communication speed between the TOP and an external device.
Data Bit	Select the serial communication data bit between the TOP and an external device.
Stop Bit	Select the serial communication stop bit between the TOP and an external device.
Parity Bit	Select the serial communication parity bit check method between the TOP and an external device.

(2) Communication option setting

■ [Control Panel] → [PLC]

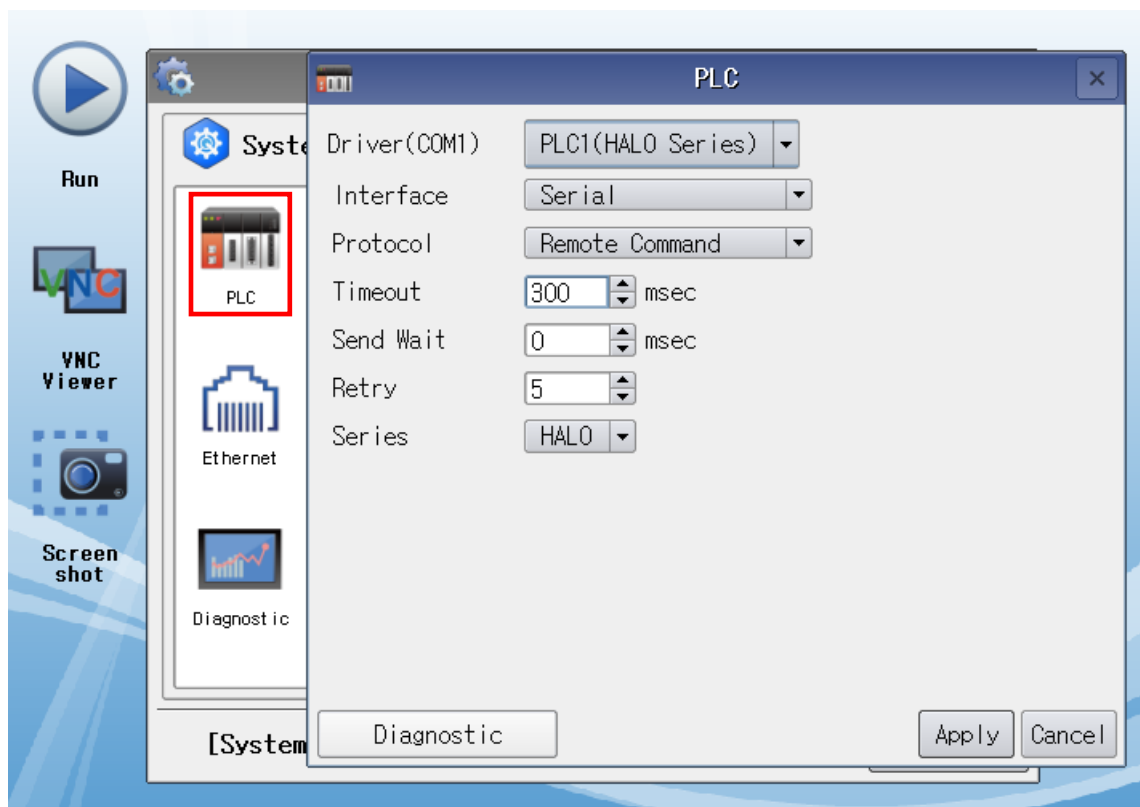

Items	Settings	Remarks
Interface	Select "Serial".	Refer to "2. External device selection".
Protocol	Select "Remote Command".	
Timeout	Set the time to wait for a response from an external device.	
Send Wait	Set the waiting time before sending a data request to an external device.	
Series	Select the series of the external device.	

3.3 Communication diagnostics

- Check the interface setting status between the TOP and an external device.
 - Touch the top of the TOP screen and drag it down. Touch "EXIT" in the pop-up window to go to the main screen.
 - Check that the settings of the connected ports in [Control Panel] → [Serial] are the same as the settings of the external device.
- Diagnosis of whether the port communication is normal or not
 - Touch "Communication Diagnostics" in [Control Panel] → [PLC].
 - Check whether communication is connected or not.

Communication diagnostics succeeded
Communication setting normal

Error message
Communication setting abnormal
 - Check the cable, TOP, and external device settings. (Refer to Communication diagnostics sheet.)

■ Communication diagnostics sheet

- If there is a problem with the communication connection with an external terminal, please check the settings in the sheet below.

Items	Contents		Check		Remarks
System configuration	How to connect the system		OK	NG	1. System configuration
	Connection cable name		OK	NG	
TOP	Version information		OK	NG	2. External device selection 3. Communication setting
	Port in use		OK	NG	
	Driver name		OK	NG	
	Other detailed settings		OK	NG	
	Relative prefix	Project setting	OK	NG	
		Communication diagnostics	OK	NG	
	Serial Parameter	Transmission Speed	OK	NG	
		Data Bit	OK	NG	
Stop Bit		OK	NG		
Parity Bit		OK	NG		
External device	CPU name		OK	NG	4. External device setting
	Communication port name (module name)		OK	NG	
	Protocol (mode)		OK	NG	
	Setup Prefix		OK	NG	
	Other detailed settings		OK	NG	
	Serial Parameter	Transmission Speed	OK	NG	
		Data Bit	OK	NG	
		Stop Bit	OK	NG	
Parity Bit		OK	NG		
Check address range		OK	NG	6. Supported addresses	

4. External device setting

- Refer to the user manual of the external device and configure the communication options.

5. Cable table

This chapter introduces a cable diagram for communication between the TOP and the external device.
(The cable diagrams in this section may differ from the vendor's recommendations.)

■ RS-232C

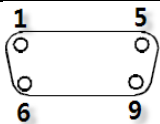
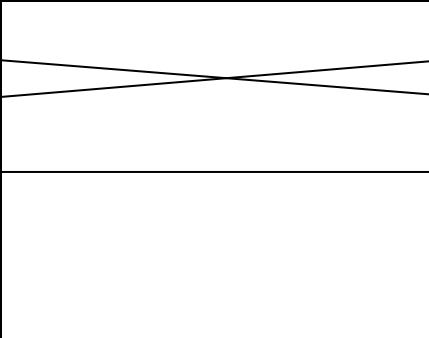
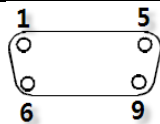
TOP			Cable connection	External device			
Pin arrangement ^{*Note 1)}	Signal name	Pin number		Pin number	Signal name	Pin arrangement ^{*Note 1)}	
 <p>Based on communication cable connector front, D-SUB 9 Pin male (male, convex)</p>		1		1		 <p>Based on communication cable connector front, D-SUB 9 Pin male (male, convex)</p>	
	RD	2		2	RD		
	SD	3		3	3		SD
		4		4	4		
	SG	5		5	5		SG
		6		6	6		
		7		7	7		
		8		8	8		
		9		9	9		

*Note 1) The pin arrangement is as seen from the connecting side of the cable connection connector.

■ RS-485

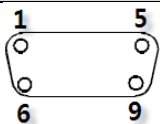
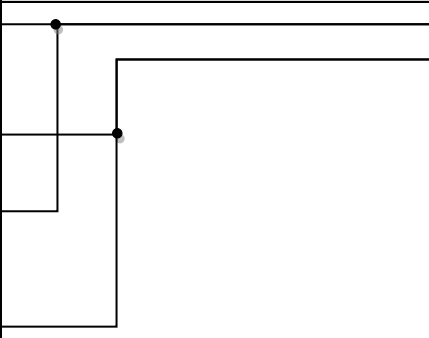
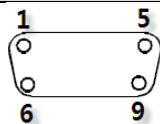
TOP			Cable connection	External device			
Pin arrangement ^{*Note 1)}	Signal name	Pin number		Pin number	Signal name	Pin arrangement ^{*Note 1)}	
 <p>Based on communication cable connector front, D-SUB 9 Pin male (male, convex)</p>	RDA	1		1	+	 <p>Based on communication cable connector front, D-SUB 9 Pin male (male, convex)</p>	
		2		2	-		
	RDB	4		4			
	SG	5		5	5		SG
	SDA	6		6	6		
		7		7	7		
		8		8	8		
	SDB	9		9	9		

*Note 1) The pin arrangement is as seen from the connecting side of the cable connection connector.

■ RS-485

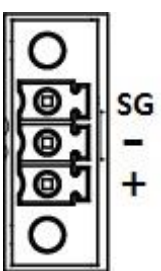
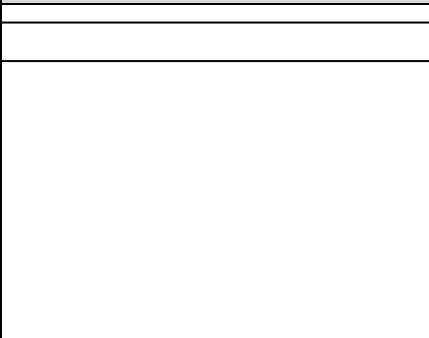
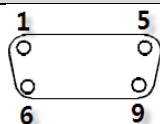
TOP		Cable connection	External device		
Pin arrangement	Signal name		Pin number	Signal name	Pin arrangement ^{*Note 1)}
	+		1	+	 <p>Based on communication cable connector front, D-SUB 9 Pin male (male, convex)</p>
	-		2	-	
	SG		3		
			4		
			5	5	
		6			
		7			
		8			
		9			

*Note 1) The pin arrangement is as seen from the connecting side of the cable connection connector.

6. Supported addresses

The addresses available in TOP are as follows:

Depending on the external device model, the supported address range may vary. Be careful not to use an address that deviates from the supported range by referring to the user manual of the external device.

* Depending on the device type, the available address may vary. Refer to the chapter "Remote Operations" in the user manual of the external device for more details.

Address	Description	Bit	Word	Data type	Remarks
CONC	Final measurement	-	CONC	FLOAT	
FILTER	Smoothing filter	-	FILTER	DEC	
GASTYPE	Gas type	-	GASTYPE	ASCII	
LOCK	Locked front display	LOCK	LOCK	BIT	
LOGINT	Data logging cycle	-	LOGINT	DEC	
OPMODE	Operation mode	-	OPMODE	DEC	*Note 1
PASSCODE	Password	-	PASSCODE	DEC	
TAU	On-peak ring download time	-	TAU	FLOAT	
TAUSTD	On-peak ring download time (Standard deviation)	-	TAUSTD	FLOAT	
TAUEMPTY	Off-peak ring download time	-	TAUEMPTY	FLOAT	
TAUESTD	Off-peak ring download time (Standard deviation)	-	TAUSTD	FLOAT	

*Note 1) Mode dependent value

Value	Mode
0	SERVICE
1	TUNE
2	MEASURE
3	SHUTDOWN