

MITSUBISHI Electric Corporation

MELSEC-Q (00CPU/01CPU) Series

CPU Direct Driver

Compatible OS Over 4.0

version

XDesignerPlus Over 4.0.0.0



CONTENTS

Thank you for using M2I's "Touch Operation Panel(M2I TOP) Series". Please read out this manual and make sure to learn connection method and process of TOP – External device"

1. System configuration Page 2



It explains device for connection, setup of, cable and structural system.

Please choose proper system referring to this point.

2. Selecting TOP model and external devices Page 3



Select TOP model and external device..

3. Example of system settings Page 4

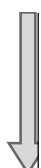

It explains setup example for communication connection between the device and external terminal.

Select example according to the system you choose in "1. System structure"

4. Communication settings details Page 5

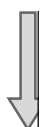

It explains the way of configuring TOP communication.

If external setup is changed, make sure to have same setup of TOP with external device by referring to this chapter.

5. Cable diagram Page 8



Explains cable specifications required for access.

Select proper cable specifications according to the system you chose in "1. System configuration".

6. Support address Page 9

Check available addresses to communicate with external devices referring to this chapter.

1. System configuration

TOP와 “MITSUBISHI Electric Corporation – MELSEC-Q 00CPU/01CPU Series CPU Direct” 통신 시스템 구성은 아래와 같습니다.

Series	CPU	Link I/F	Method	System settings	Cable
MELSEC-Q	Q00CPU Q01CPU	CPU Port	RS-232C		

■ Connection configuration

- 1:1 connection (TOP 1 vs. external device)



2. Selecting TOP model and external devices

Select the external devices to connect to TOP.

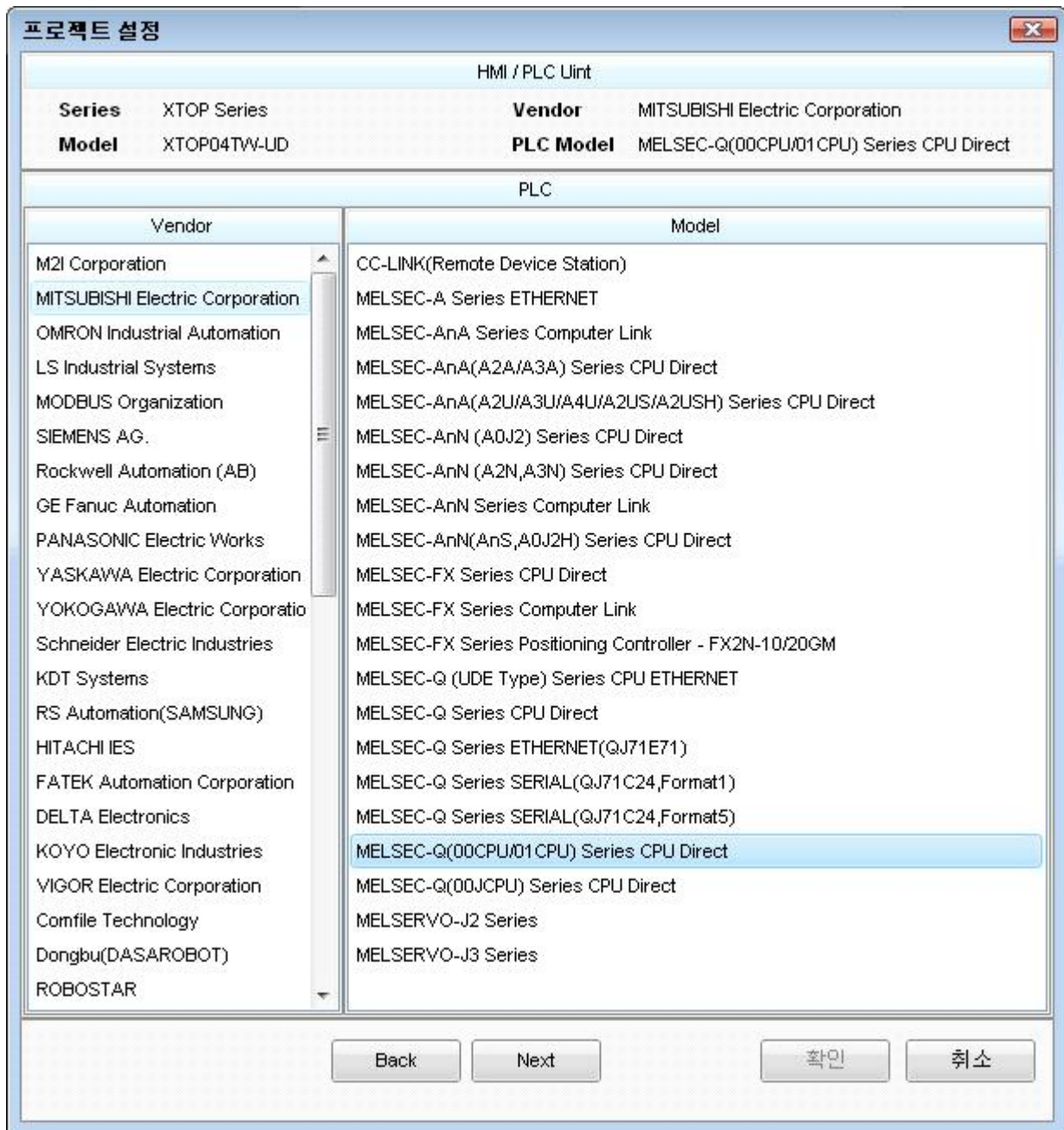

Setting details		Contents				
TOP	Series	Select the name of a TOP series that is to be connected to PLC. Before downloading the settings, install the OS version specified in the table below according to TOP series. <table border="1" style="margin-left: 20px;"> <thead> <tr> <th>Series</th> <th>Version name</th> </tr> </thead> <tbody> <tr> <td>XTOP / HTOP</td> <td>V4.0</td> </tr> </tbody> </table>	Series	Version name	XTOP / HTOP	V4.0
	Series	Version name				
XTOP / HTOP	V4.0					
Name	Select the model name of TOP product.					
Communication Device	Manufacturer	Select the manufacturer of external devices to be connected to TOP. Please Choose " <u>MITSUBISHI Electric Corporation</u> ".				
	PLC	Select the model series of external devices to be connected to TOP. Please select " <u>MELSEC-Q(00CPU/01CPU) Series CPU Direct</u> ".				

		Please check, in the "1. System configuration", if the relevant external device is available to set a system configuration.
--	--	---

3. Example of system settings

Regarding of communication interface settings in TOP and external devices, we suggest as below.

3.1 Example of settings 1

The system is set as below.

Details	TOP	MELSEC-Q 00CPU/01CPU SERIES	Remark
Serial level (port/channel)	RS-232 (COM2)	RS-232 (CPU port)	Fixed
Serial baud rate [BPS]	115200		User settings
Serial data bit [Bit]	8		Fixed
Serial stop bit [Bit]	1		Fixed
Serial parity bit [Bit]	ODD		Fixed

(1) XDesignerPlus setup

After setting the below details in [Project > Project Settings], download the detailed settings using TOP tool.

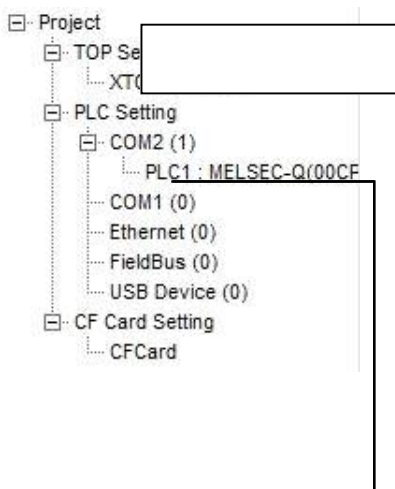

■ [Project > Project property > Project > Settings > TOP Name]

Set the communication interface of TOP tool.

- From right window [HMI Setup > check Use HMI Setup > Device Manager]



■ External device settings

This sets the option of Communication Driver in "MELSEC-Q(00CPU/01CPU) Series CPU Direct".



- PLC Address : External Device Setting Address
- Block process method : Choose the protocol method.
- Module : Choose the subject to be communicated.

(2) External device settings

The loader port communication interface of MELSEC-Q 00CPU/01CPU SERIES does not need extra setting. Communication speed will be automatically sets depends on TOP's setting speed.

4. Communication settings details

Communication settings are available at XDesignerPlus or TOP main menu. Communication settings must be identical with the external devices.

4.1 XDesignerPlus settings details

Select [Project > Project property] to show the below window.

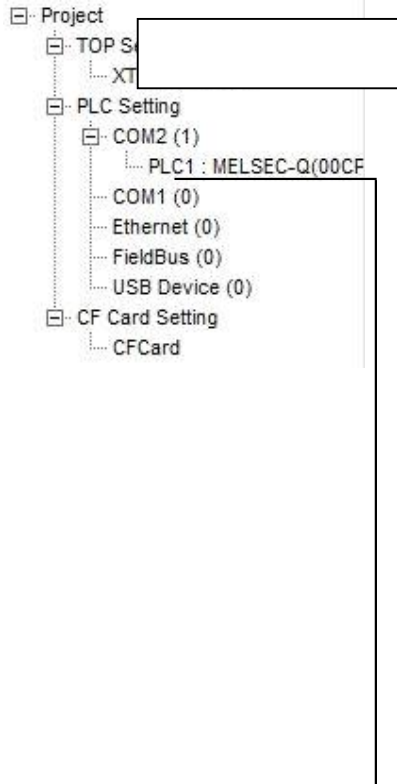

■ [Project > Project property > Project > Settings > TOP Name]

Set the communication interface of TOP tool.

- From right window, [HMI Setup > Check Use HMI setup > Device Manager]

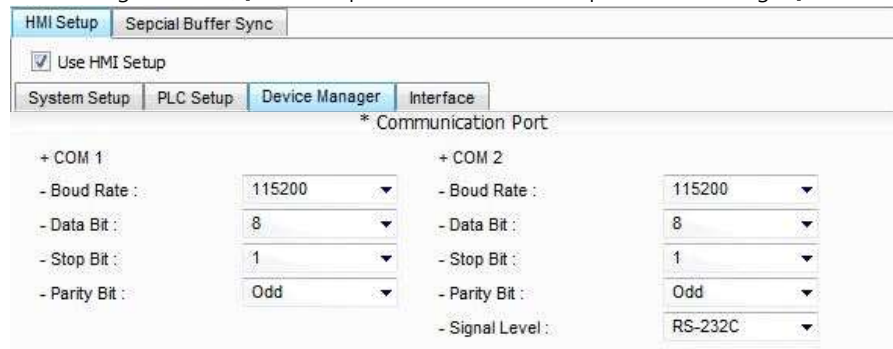

- From right window [HMI Setup > Check Use HMI Setup > PLC Setup]

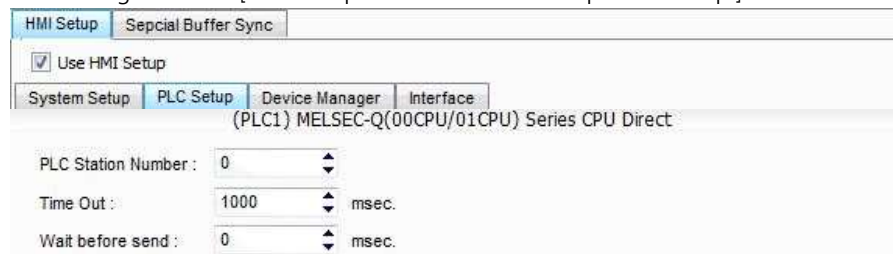

■ External device settings

This sets the option of Communication Driver in "MELSEC-Q(00CPU/01CPU) Series CPU Direct".



■ Communication Interface Settings

Details	Contents
Signal level	External device – select serial communication method between TOPs. (COM1 supplies RS-232C only)
Baud rate	External device – select serial communication speed between TOPs.
Data bit	External device – select serial communication data bit between TOPs.
Stop bit	External device – select serial communication stop bit between TOPs.
Parity bit	External device – select serial communication parity bit check method between TOPs.
Time out [x100 mSec]	Set up TOP's waiting time from external device at [0 - 5000] x 1mSec.
Transmitting Delay Time [x10 mSec]	Set up TOP's waiting time between response receiving – next command request transmission from external device at [0 – 5000] x 1 mSec.
Receiving Wait Time [x10 mSec]	

PLC address [0~65535]

Address of other device. Select between [0 - 65535].

4.2 TOP main menu setup item

- When a buzzer is on during the power reset, touch 1 spot at the upper LCD to move to "TOP Management Main" display.
- Set up driver interface at TOP according to below Step1 → Step2.
(Press "TOP COM 2/1 setup" in Step 1 to change setup at Step 2.)

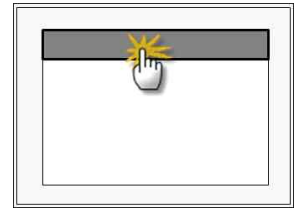

Step 1. [PLC setup] .Setup driver interface.

PLC setup		
PLC Address : 00	Communication Interface Settings	
Timeout : 1000 [mSec]		
Delay time of transmission : 0 [mSec]		
TOP COM 2/1 : RS - 232C , 115200 , 8 , 1 , ODD		
<table border="1"> <tr> <td>TOP COM 2/1 setup</td> <td>communication test</td> </tr> </table>		TOP COM 2/1 setup
TOP COM 2/1 setup	communication test	

Step 1-Reference.

Details	Contents
PLC address [0~65535]	Address of other device. Select between [0 - 65535].
Timeout [x1 mSec]	Set up TOP's waiting time from external device at [0 - 5000] x 1mSec.
Delay time of transmission [x1 mSec]	Set up TOP's waiting time between response receiving – next command request transmission from external device at [0 – 5000] x 1 mSec.
TOP COM 2/1	TOP's Interface setup to external device.

Step 2. [PLC setup] >[TOP COM2/COM1 setup] – Setup relevant port's serial parameter.

Port Settings	
* Serial communication + COM-1 Port - Baud Rate : 115200 [BPS] - Data bit : 8 [BIT] - Stop bit : 1 [BIT] - Parity Beat : ODD [BIT] - Signal level : RS – 232C	COM 1 Port Communication Interface Settings
+ COM-2 Port - Baud Rate : 115200 [BPS] - Data bit : 8 [BIT] - Stop bit : 1 [BIT] - Parity Beat : ODD [BIT] - Signal level : RS – 232C	COM-2 Port Communication Interface Settings

Step 2-Reference.

Details	Contents
Baud rate	External device – select serial communication speed between TOPs.
Data bit	External device – select serial communication data bit between TOPs.
Stop bit	External device – select serial communication stop bit between TOPs.
Parity bit	External device – select serial communication parity bit check method between TOPs.
Signal level	External device – select serial communication method between TOPs.

4.3 Communication diagnosis

- TOP - Confirming interface setting condition between external devices
 - Move to Menu by clicking the top side of LCD screen as resetting the power of TOP.
 - Confirms if Port [COM 2 or COM 1] setting that is willing to use in [Communication Settings] matches with the setting of external devices.
- Port communication diagnosis
 - PLC Setting > TOP [COM 2 or COM 1] click "[Communication Diagnosis](#)" button.
 - Diagnosis dialog box will pop up on the screen, you can judge by following information that are shown on box no. 3 section.

OK! Communication setting succeeded

Time Out Error! Communication setting error
 - Error in the setting situation of Cable and TOP / External device
(reference : Communication Diagnosis sheet)

■ Communication Diagnosis Sheet

- Please refer to the information below if you have a problem between external devices and communication connection.

Designer Version		O.S Version				
Details	Contents			Confirm		
System configuration	Name of CPU				OK	NG
	Name of confront port that is communicating				OK	NG
	System Connection Method	1:1	1:N	N:1	OK	NG
Connection Cable	Name of Cable				OK	NG
PLC setup	Setup address				OK	NG
	Serial baud rate	[BPS]			OK	NG
	Serial data bit	[BIT]			OK	NG
	Serial Stop bit	[BIT]			OK	NG
	Serial parity bit	[BIT]			OK	NG
	Assigned Address Limit				OK	NG
TOP setup	Setup port	COM 1	COM 2		OK	NG
	Name of Driver				OK	NG
	Confront Address	Project Property Setup			OK	NG
		Diagnosing Communication			OK	NG
	Serial baud rate	[BPS]			OK	NG
	Serial data bit	[BIT]			OK	NG
	Serial Stop bit	[BIT]			OK	NG
	Serial parity bit	[BIT]			OK	NG

5. Cable

This Chapter describes the cable connection for communication between TOP and relative devices. (Cable diagram that are being in this chapter are based on the suggestions of "Mitsubishi Electric Corporation".)

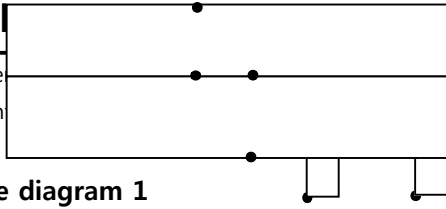

5.1 Cable diagram 1

■ 1 : 1 Connection

(A) XTOP COM 2 Port (9 pin)

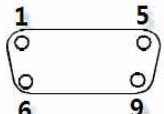
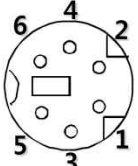
XTOP COM2			Cable Connection	PLC		
pin arrangement * caution 1)	Name of Signal	Pin Number		Pin Number	Name of Signal	pin arrangement * caution 1)
 <p>Front View of D-SUB 9 Pin male (Male, convex)</p>	CD	1	1	RD	 <p>Front View of D-SUB 6 Pin male (Male, convex)</p>	
	RD	2	2	SD		
	SD	3	3	SG		
	DTR	4	4			
	SG	5	5	DSR		
	DSR	6	6	DTR		
	RTS	7				
	CTS	8				
		9				

*Caution1) Pin arrangement is shown from connecting face in cable connection connector.

(B) XTOP COM 2 Port (15 pin)

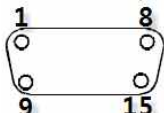
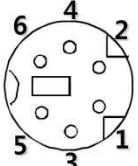
XTOP COM2			Cable Connection	PLC		
pin arrangement * caution 1)	Name of Signal	Pin Number		Pin Number	Name of Signal	pin arrangement * caution 1)
 <p>Front View of D-SUB 9 Pin (Male, convex)</p>	CD	1	1	RD	 <p>Front View of D-SUB 6 Pin (Male, convex)</p>	
	RD	2	2	SD		
	SD	3	3	SG		
	DTR	4	4			
	SG	5	5	DSR		
	DSR	6	6	DTR		
	RTS	7				
	CTS	8				
		9				

*Caution1) Pin arrangement is shown from connecting face in cable connection connector.

(C) XTOP/ATOP COM 1 Port (6 Pin)

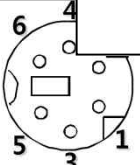
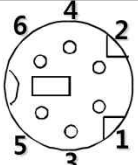
XTOP/ATOP COM 1 Port (6 Pin)			Cable Connection	PLC		
pin arrangement * caution 1)	Name of Signal	Pin Number		Pin Number	Name of Signal	pin arrangement * caution 1)
 <p>Front View of D-SUB 6 Pin (Male, convex)</p>	RD	2	1	RD	 <p>Front View of D-SUB 6 Pin (Male, convex)</p>	
	SG	3	2	SD		
		4	3	SG		
		5	4			
			5	DSR		

D-SUB 6 Pin (Male, convex)	SD	6		6	DTR	MINI-DIN 6 Pin (Male, convex)

*Caution1) Pin arrangement is shown from connecting face in cable connection connector.

6. Support address

Devices that are usable with TOP is as below.

There might be difference in the range of device (address) by type / series of CPU module TOP series supports the maximum address range that external device series use Please refer each CPU module user manual carefully for devices that you desired to use to prevent not getting out of range.

Device	Bit Address	Word Address	Word Address NOTE	32 BIT
Input Relay	X0000 - X1FFF (HEX)	X0000 - X1FF0 (HEX)	X***0 *caution1)	L/H *caution3)
Output Relay	Y0000 - Y1FFF (HEX)	Y0000 - Y1FF0 (HEX)	Y***0 *caution1)	
Internal Relay	M0000 - M32767	M0000 - M32752	M0000 + 16*n *caution2)	
Special Relay	SM0000 - SM2047	SM0000 - SM2032	SM0000+16*n *caution2)	
Latch Relay	L0000 - L32767	L0000 - L32752	L0000 + 16*n *caution2)	
Annunciator	F0000 - F32767	F0000 - F32752	F0000 + 16*n *caution2)	
Edge Relay	V0000 - V32767	V0000 - V32752	V0000 + 16*n *caution2)	
Step Relay	S0000 - S8191	S0000 - S8176	S0000 + 16*n *caution2)	
Link Relay	B0000 - B7FFF (HEX)	B0000 - B7FF0 (HEX)	B***0 *caution1)	
Special Link Relay	SB000 - SB7FF (HEX)	SB000 - SB7F0 (HEX)	SB***0 *caution1)	
Timer (contact)	TS00000 - TS23087			
Timer (coil)	TC00000 - TC23087			
Aggregate Timer (contact)	SS00000 - SS23087			
Aggregate Timer (coil)	SC00000 - SC23087			
Counter (contact)	CS00000 - CS23087			
Counter (coil)	CC00000 - CC23087			
Timer (current value)		TN00000 - TN23087		
Aggregate Timer (current value)		SN00000 - SN23087		
Counter (current value)		CN00000 - CN23087		
Data Register		D00000 - D25983		
Special Data Register		SD0000 - SD2047		
File Register		☞ User Defined Range		

*Caution1) If the bit address is hexadecimal number '0~F', starting bit 0 bit shall be used as word address.

*Caution2) If the bit address is decimal number, it shall be used as word address by every value of '16'.

*Caution3) The address will be saved where the 16BIT data which is subordinate to 32BIT data monitor registered and super ordinate 16BIT data will be saved right after the address that is monitor registered.

Ex) If 32BIT data, 16 hexadecimal data 12345678 is saved to the address number D00100, it shall be saved with 16BIT device address as below.

Details	32BIT	16BIT	
	Address	D00100	D00101
Input data (Hexadecimal Number)	12345678	5678	1234