

LS Industrial Systems Co., Ltd.

XGT(XGK-CPU), XGB(XBC-CPU/XBM-CPU) Series

CPU Direct Driver

Support version OS V4.0 and over



XDesignerPlus 4.0.0.0 and over

CONTENTS

Thank you for using TOP series of M2I corporation.

Please read this manual carefully to know connection methods and procedures of "TOP to External device".

1. System configuration Page 2



A section for showing connectable external devices, serial signal types, connection configurations. Refer this section to select the right system configuration.

2. Selection of TOP, External device Page 3



A section for selecting a Top model and the external device.

3. Example of system setting Page 4

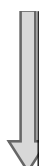

A section for explaining examples to connect communications of TOP to External Device.

Select the correct example in your case according to "1. System configuration".

4. Communication setting Page 5

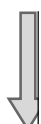

A section for Communication setting.

The setting should be the same with the external device.

5. Cable diagram Page 8



A section for cable to connect to external device.

Select a suitable cable diagram for your system.

6. Usable address Page 10

A section for usable address to communicate with external device.

1. System configuration

System configuration of TOP and "LS Industrial Systems Co., Ltd – XGT(XGK), XGB(XBC/XBM) Series"

Series	CPU*1)	Link I/F	Comm. type	System setting	Cable
XGK	XGK-CPUH XGK-CPUA XGK-CPUS XGK-CPUE XGK-CPUU	PADT connection connector (9pin) *2)	RS232	setting ex 1 (4 page)	cable diagram 1 (8 page)
XGB	XBM-D□16S XBM-D□32S XBC-D□32H XBC-D□64H	PADT connection connector (6pin) *2)	RS232	setting ex 1 (4 page)	cable diagram 2 (9 page)

*1) Confirm that version written CPU unit label is 1.1 and over.

*2) PADT connection connector : PLC CPU connector of PC Ladder S/W XG5000

■ Connection configuration (TOP number : External number)

• 1 : 1(TOP 1 unit to External device 1 unit) connection – It is available with RS232C.



2. Selection of TOP, External device

Select a external device which is communicated to the TOP.

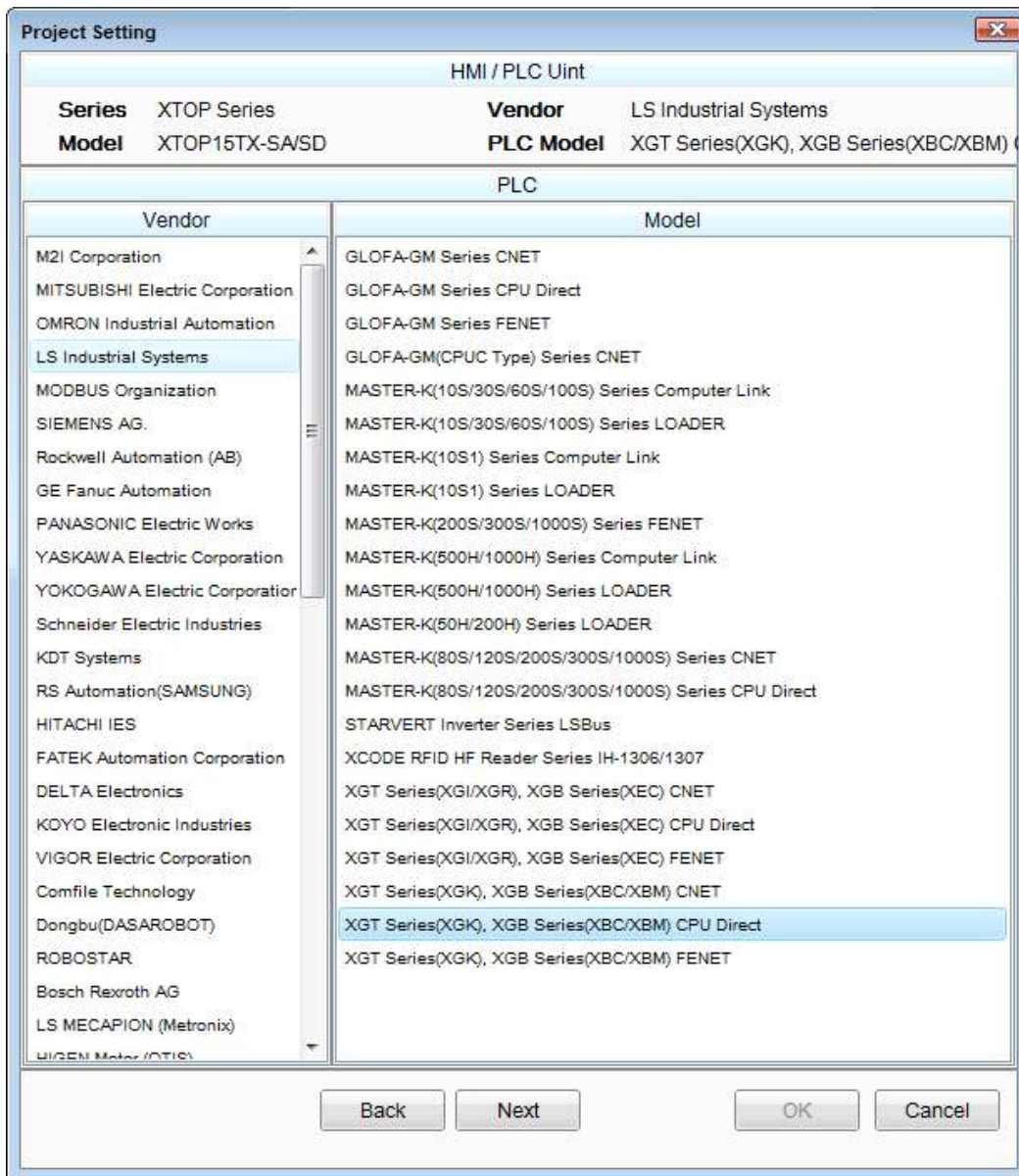

Setting Items		Description				
TOP	Series	Select a TOP series which is communicated with external device. Install an OS file v3.1 as diagram below before download a project file you have made. <table border="1" data-bbox="512 1644 1150 1733"> <tr> <td>Series</td> <td>OS Version</td> </tr> <tr> <td>XTOP / HTOP</td> <td>V4.0</td> </tr> </table>	Series	OS Version	XTOP / HTOP	V4.0
	Series	OS Version				
XTOP / HTOP	V4.0					
	Name	Select a TOP model which is communicated with external device.				
External Device	Vendor	Select vendor of the external device which is communicated with TOP. Select " <u>LS Industrial Systems Co., Ltd</u> ".				
	PLC	Select a model name of the external device which is communicated with TOP. Select " <u>XGT(XGK), XGB(XBC/XBM) Series CPU Direct</u> ". Check whether the external device you want to use is connectable or not in "1. System configuration".				

3. Example of system setting

Set Communication interface of TOP and external device as below.

3.1 Example 1

Set your system as below.

Item	TOP	XGT Series	Note
Serial Signal Level (port/channel)		RS-232	fixation
Serial Baud rate [BPS]		115200	fixation
Serial Data bit [Bit]		8	fixation
Serial Stop bit [Bit]		1	fixation
Serial Parity bit [Bit]		NONE	fixation

(1) XDesignerPlus Setting

[Project > Project property] of XDesignerPlus as below and download it to TOP machine.

■ [Project > Project property > project > TOP Setting > TOP's Name]
Set communication interface of TOP.
- From right window [HMI Setup > check Use HMI Setup > Device Manager]

* Communication Port

+ COM 1	+ COM 2
- Boud Rate : 115200	- Boud Rate : 115200
- Data Bit : 8	- Data Bit : 8
- Stop Bit : 1	- Stop Bit : 1
- Parity Bit : None	- Parity Bit : None
	- Signal Level : RS-232C

■ External Device Settings

Set up the "XGT(XGK), XGB(XBC/XBM) Series CPU Direct" communication option

PLC Comm Info

Station Number(PLC) 0

CPU Type XGB

- PLC Address : External setting station number (Don't use this option)
- CPU Type : Set up the CPU Type

(2) External device setup

Setting value of loader communication port interface of "XGT(XGK), XGB(XBC/XBM) Series" is fixed.

4. Communication setting

Communication setup can be set on XDesignerPlus or TOP Main Menu. The setting should be the same with the external device.

4.1 XDesignerPlus Setup

Set [Project >Project property] of XDesignerPlus as below and download TOP machine.

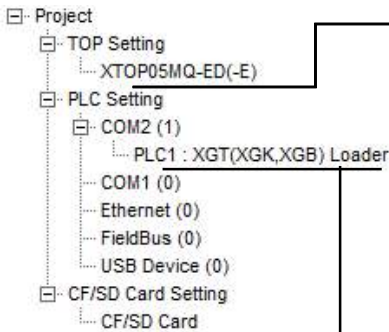

■ [Project > Project property > project > TOP Setting > TOP's Name]

Set communication interface of TOP.

- From right window [HMI Setup > check Use HMI Setup > Device Manager]

- From right window [HMI Setup > check Use HMI Setup > PLC Setting]

■ External Device Settings

Set up the "XGT(XGK), XGB(XBC/XBM) Series CPU Direct" communication option

■ Setting communication Interface

Item	Description
Serial Signal Level	Setup signal level(RS-232C/422/485) of PLC connected with COM2/1 port. (COM1 only RS-232C)
Serial Baud Rate	Setup [communications Baud rate] of PLC connected with COM2/1 port.
Serial Data Bit	Setup [Data Bit] of PLC connected with COM2/1 port.
Serial Stop Bit	Setup [Stop Bit] of PLC connected with COM2/1 port.
Serial Parity Bit	Setup [Parity Bit] of PLC connected with COM2/1 port.
Time Out [x100 mSec]	Setup [Time Out] of PLC connected with COM2/1 port. (Timeout:: waiting time for answer of PLC)
Send Wait [x10 mSec]	Setup [Send Wait] of PLC connected with COM2/1 port. (Send Wait: communicate after waiting setting time when touch screen requires communications.)
Station Num. in Diag.[0~31]	Out of use

4.2 TOP main menu setup item

- When a buzzer is on during the power reset, touch 1 spot at the upper LCD to move to "TOP Management Main" display.
- Set up driver interface at TOP according to below **Step1** → **Step2**.
(Press "TOP COM 2/1 setup" in **Step 1** to change setup at **Step 2**.)

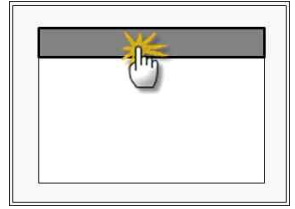

Step 1. [PLC setup] - Setup driver interface.

PLC setup	
PLC Address : 00	Communication Interface Settings
Timeout : 1000 [mSec]	
Delay time of transmission : 0 [mSec]	
TOP COM 2/1 : RS – 232C , 115200 , 8 , 1 , NONE	
TOP COM 2/1 setup communication test	

Step 1-Reference.

Details	Contents
PLC address [0~65535]	Address of other device. Select between [0 - 65535].
Timeout [x1 mSec]	Set up TOP's response waiting time from external device at [0 – 5000] x 1 mSec.
Delay time of transmission [x1 mSec]	Set up TOP's waiting time between response receiving – next command request transmission from external device at [0 – 5000] x 1 mSec.
TOP COM 2/1	TOP's Interface setup to external device.

Step 2. [PLC setup] > [TOP COM2/COM1 setup] – Setup relevant port's serial parameter.

Port Settings	
* Serial communication	COM 1 Port Communication Interface Settings
+ COM-1 Port	
- Baud rate : 115200 [BPS]	COM-2 Port Communication Interface Settings
- Data bit : 8 [BIT]	
- Stop bit : 1 [BIT]	
- Parity bit : NONE [BIT]	
- Signal level : RS – 232C	
+ COM-2 Port	
- Baud rate : 115200 [BPS]	COM-2 Port Communication Interface Settings
- Data bit : 8 [BIT]	
- Stop bit : 1 [BIT]	
- Parity bit : NONE [BIT]	
- Signal level : RS – 232C	
- Signal level : RS – 232C	

Step 2-Reference.

Details	Contents
Baud rate	External device – select serial communication speed between TOPs.
Data bit	External device – select serial communication data bit between TOPs.
Stop bit	External device – select serial communication stop bit between TOPs.
Parity bit	External device – select serial communication parity bit check method between TOPs.
Signal level	External device – select serial communication method between TOPs.

4.3 Communication Diagnosis

- TOP - Confirming interface setting condition between external devices
 - Move to Menu by clicking the top side of LCD screen as resetting the power of TOP.
 - Confirms if Port [COM 2 or COM 1] setting that is willing to use in [Communication Settings] matches with the setting of external devices.
- Port Communication Issue Diagnosis
 - PLC Setup > TOP [COM 2 or COM 1] click "[Communication Diagnosis](#)" button.
 - Diagnosis dialog box will pop up on the screen, you can judge by following information that are shown on box no. 3 section.

OK! Communication setting succeeded

Time Out Error! Communication setting error
 - Error in the setting situation of Cable and TOP / External device
(reference : Communication Diagnosis sheet)

- Communication Diagnosis Sheet
 - Please refer to the information below if you have a problem between external devices and communication connection.

Designer Version		O.S Version				
Details	Contents				Confirm	
System configuration	Name of CPU				OK	NG
	Name of confront port that is communicating				OK	NG
	System Connection Method	1:1	1:N	N:1	OK	NG
Connection Cable	Name of Cable				OK	NG
PLC setup	Setup address				OK	NG
	Serial baud rate	[BPS]			OK	NG
	Serial data bit	[BIT]			OK	NG
	Serial Stop bit	[BIT]			OK	NG
	Serial parity bit	[BIT]			OK	NG
	Assigned Address Limit				OK	NG
TOP setup	Setup port	COM 1	COM 2		OK	NG
	Name of Driver				OK	NG
	Confront Address	Project Property Setup			OK	NG
		Diagnosing Communication			OK	NG
	Serial baud rate	[BPS]			OK	NG
	Serial data bit	[BIT]			OK	NG
	Serial Stop bit	[BIT]			OK	NG
Serial parity bit	[BIT]			OK	NG	

5. Cable diagram

This Chapter introduces cable wiring guidance for communication between TOP and PLC concerned. (The cable diagrams in this section may differ from the recommendations of "LS Industrial Systems, Ltd.")

5.1 Cable Diagram Table 1

■ 1 : 1 Connection

(A) XTOP COM 2 port(9pin)

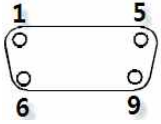
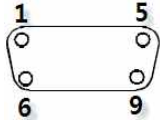
XTOP COM2			Cable Wiring	PLC			
Pin Assignment *1)	Signal	Pin No		Pin No	Signal	Pin Assignment *1)	
 <p>Front View of D-SUB 9 Pin (male, convex)</p>	CD	1		1	CD	 <p>Front View of D-SUB 9 Pin (male, convex)</p>	
			2		2		
	RD				RD		
	SD	3		3	SD		
	DTR	4		4	DTR		
	SG	5		5	SG		
	DSR	6		6	DSR		
	RTS	7		7	RTS		
	CTS	8		8	CTS		
		9		9			

*1) Pin assignment of the cable connector is seen on the face of Front View.

(B) XTOP COM 2 port(15pin)

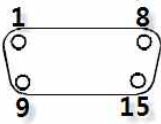
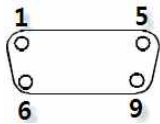
XTOP COM2			Cable Wiring	PLC			
Pin Assignment *1)	Signal	Pin No		Pin No	Signal	Pin Assignment *1)	
 <p>Front View of D-SUB 15 Pin (male, convex)</p>	CD	1		1	CD	 <p>Front View of D-SUB 9 Pin (male, convex)</p>	
			2		2		RD
	SD	3		3	SD		
	DTR	4		4	DTR		
	SG	5		5	SG		
	DSR	6		6	DSR		
	RTS	7		7	RTS		
	CTS	8		8	CTS		
			9		9		

*1) Pin assignment of the cable connector is seen on the face of Front View.

(C) XTOP/ATOP COM 1 port(6pin)

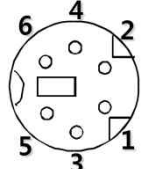
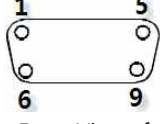
XTOP/ATOP COM 1 port			Cable Wiring	PLC		
Pin Assignment *1)	Signal	Pin No		Pin No	Signal	Pin Assignment *1)
		1		1	CD	 <p>Front View of D-SUB 9 Pin</p>
	RD			2	RD	

Front View of D-SUB 6 Pin (male, convex)		2				(male, convex)
	SG	3		3	SD	
		4		4	DTR	
		5		5	SG	
	SD	6		6	DSR	
				7	RTS	
				8	CTS	
				9		

*1) Pin assignment of the cable connector is seen on the face of Front View.

5.2 Cable Diagram Table 2

■ 1 : 1 Connection

(A) XTOP COM 2 port(9pin)

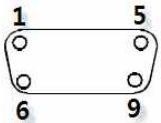
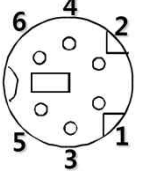
XTOP COM2			Cable Wiring	PLC		
Pin Assignment *1)	Signal	Pin No		Pin No	Signal	Pin Assignment *1)
 <p>Front View of D-SUB 9 Pin (male, convex)</p>	CD	1		1		 <p>Front View of D-SUB 6 Pin (male, convex)</p>
	RD	2		2	RD	
	SD	3		3	SG	
	DTR	4		4		
	SG	5		5		
	DSR	6		6	SD	
	RTS	7				
	CTS	8				
		9				

*1) Pin assignment of the cable connector is seen on the face of Front View.

(B) XTOP COM 2 port(15pin)

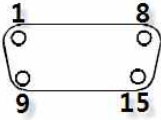
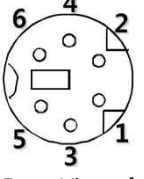
XTOP COM2			Cable Wiring	PLC		
Pin Assignment *1)	Signal	Pin No		Pin No	Signal	Pin Assignment *1)
 <p>Front View of D-SUB 15 Pin (male, convex)</p>	CD	1		1		 <p>Front View of D-SUB 6 Pin (male, convex)</p>
	RD	2		2	RD	
	SD	3		3	SG	
	DTR	4		4		
	SG	5		5		
	DSR	6		6	SD	
	RTS	7				

	CTS	8		
		9		

*1) Pin assignment of the cable connector is seen on the face of Front View.

(C) XTOP/ATOP COM 1 port(6pin)

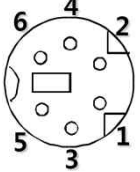
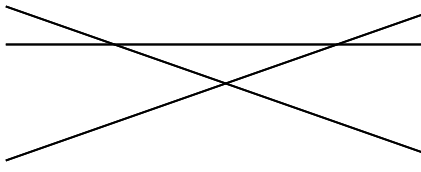
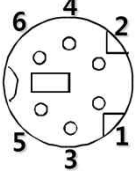
XTOP/ATOP COM 1 port			Cable Wiring	PLC		
Pin Assignment *1)	Signal	Pin No		Pin No	Signal	Pin Assignment *1)
 <p>Front View of D-SUB 6 Pin (male, convex)</p>		1		1		 <p>Front View of D-SUB 6 Pin (male, convex)</p>
	RD	2		2	RD	
	SG	3		3	SG	
		4		4		
		5		5		
	SD	6		6	SD	

*1) Pin assignment of the cable connector is seen on the face of Front View.

6. Available Address

The available address of device are as below.

Device(address) range might be different according to series/type of CPU. TOP Series are capable of supporting maximum address range which is available in external Device.

Be careful get out of address range.

Device	Bit Address	Word Address	32 Bit	Property
Input / Output Relay	P00000 – P2047F	P0000 – P2047	L/H ^{*1)}	R/W
Auxiliary Relay	M00000 – M2047F	M0000 – M2047		R/W
Keep Relay	K00000 – K2047F	K0000 – K2047		R/W
Link Relay	L000000 – L11263F	L00000 – L11263		R/W
Special Relay	F00000 – F2047F	F0000 – F2047		R
Timer (Contact)	T0000 – T2047	—————		R/W
Counter (Contact)	C0000 – C2047	—————		R/W
Timer (Current Value)	—————	T0000 – T2047		R/W
Counter (Current Value)	—————	C0000 – C2047		R/W
Data Register	D00000.00 – D65535.15	D00000 – 65535		R/W
Communication Data Register	N00000.00 – D65535.15	N00000 – N21503		R/W
File Register	R00000.00 – R32767.15	R00000 – R32767		R/W
File Register	ZR00000.00 – ZR65535.15	ZR00000 – ZR65535		R/W

R:read / W:write

*1) Low 16BIT of 32BIT data is saved address input by touch program, high 16Bit of 32BIT data is saved next address input by touch program.

(Ex) If you input [12345678] of hex 32bit data at address [D00100], it will save in 16bit device as below.

Item	32BIT	16BIT	
	address	D00100	D00101
Input data(Hex)	12345678	5678	1234